

MITSUBISHI ELECTRIC CORPORATION
PUBLIC RELATIONS DIVISION
 7-3, Marunouchi 2-chome, Chiyoda-ku, Tokyo, 100-8310 Japan

FOR IMMEDIATE RELEASE

No. 3220

Customer Inquiries

Media Inquiries

Advanced Technology R&D Center
 Mitsubishi Electric Corporation
www.MitsubishiElectric.com/ssl/contact/company/rd/form.html
www.MitsubishiElectric.com/company/rd/

Public Relations Division
 Mitsubishi Electric Corporation
prd.gnews@nk.MitsubishiElectric.co.jp
www.MitsubishiElectric.com/news/

Mitsubishi Electric’s New Energy-management Technology Uses Electric Vehicles as Storage Batteries

Lowers electric power costs by optimizing EV charging and discharging

TOKYO, October 25, 2018 – [Mitsubishi Electric Corporation](http://www.mitsubishielectric.com) (TOKYO: 6503) announced today that it has developed a technology for efficiently managing photovoltaic (PV) and other power-generation systems and also the charging/discharging of electric vehicles (EVs) parked on company campuses. By optimizing the schedules for not only charging EVs but also discharging their power back into the company, as well as optimizing the operation of PV and other power-generation systems according to the fluctuating unit price of electricity sold on the grid, Mitsubishi Electric’s new system enables companies to reduce their electric-power costs.

This November, Mitsubishi Electric and its affiliate Mitsubishi Electric (China) Co., Ltd. will conduct a joint-demonstration test of the new technology at the factory of Mitsubishi Electric Automotive (China) Co., Ltd. in Changshu in China, where the use of EVs is expected to advance rapidly.

Going forward, Mitsubishi Electric will continue research and development of its new energy-management technology aiming for even higher efficiency and performance. Further, by combining the technology with the company’s energy management systems it expects to continuously expand its energy related business.

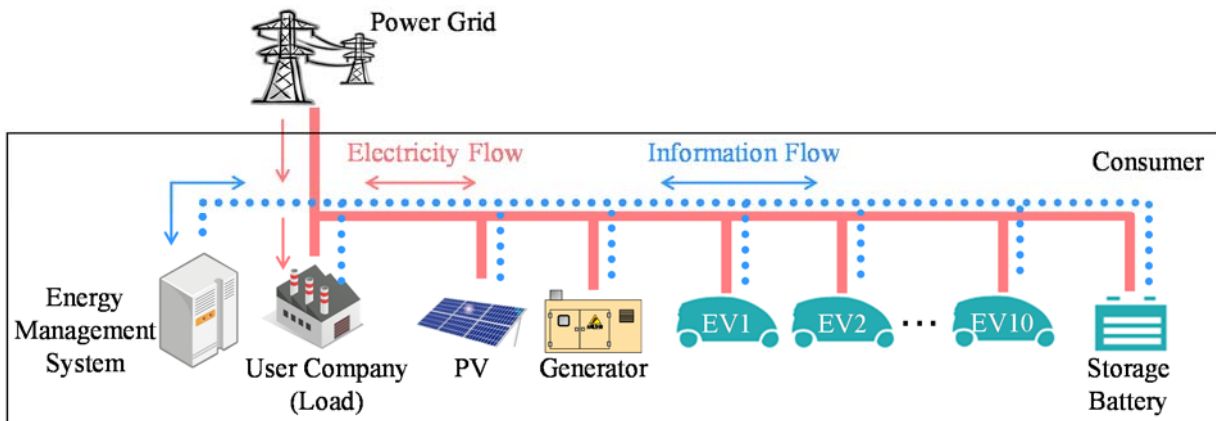

Fig. 1 Energy-management system for power generation and power storage

Features

1) Reduces users' electric power costs by 5% by optimizing EV charging/discharging schedules

Mitsubishi Electric's new solution uses a multi-directional power conditioning system (PCS) to reduce or shift the use of grid power during peak hours by calculating minimized power costs, coordinating the charging/discharging of EVs parked at the user's company with the use of PV and other power-generation systems, and forecasting power demand and PV power generation. A mathematical programming embedding a proprietary model is used to calculate an optimized plan for on-site power generation and EV charging/discharging based on inputs such as contracted power from the grid, electricity unit prices, power demand and expected use of EVs in the fleet under the constraints of the received-power capacity, supply-demand balance, and the maximum and minimum charge/discharge levels of EVs and on-site storage batteries (Fig. 2).

Conventional energy-management systems set a threshold to prevent the user's power demand from exceeding its contracted power from the grid. EVs are charged in advance, allowing them to be discharged if power demand exceeds the threshold. However, if a number of EVs must be used off-site unexpectedly, this can result in the need to charge EVs when the electricity unit price is still relatively high.

In simulations using a scaled-down 1:10 model of a 1,000-employee factory, typical power demand, and EV usage, power costs in the case of using 10 EVs were found to be 5 percent less than in the case of using no energy-management system.

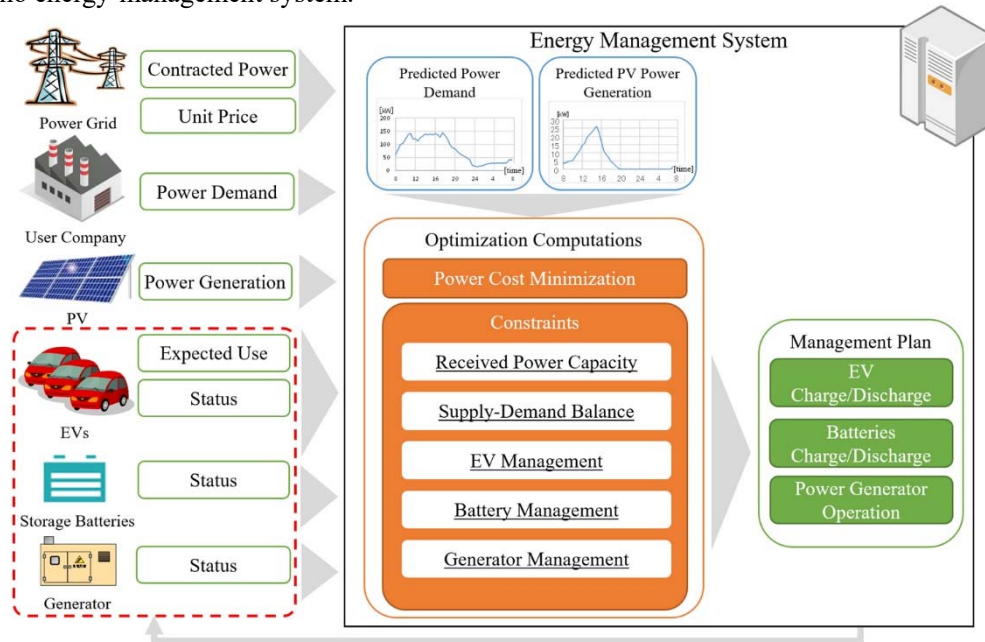

Fig. 2. Power cost minimization in energy-management system

2) Uses multi-step control to minimize electric power cost increases in case of unexpected EV usage

The EV operation plan and charge/discharge schedule are regularly optimized through the use of a “one-day plan” that is calculated several times each day to establish the charge/discharge schedule for the next 24 hours, a “correction plan” calculated every several minutes to refine plans for the next several hours, and a “control command” calculated every several seconds (Fig. 3). Concurrently, the system continuously monitors the amount of electricity purchased from the grid and the state of charge of EVs parked on the company's campus.

Conventional energy-management systems correct plans when PV power generation or power demand deviate significantly from the projected one-day plan. However, since these systems do not make allowances for factors such as delays in EVs arriving at the company or undercharged EVs, purchasing power during peak hours sometimes becomes unavoidable, resulting in higher costs to the company.

Mitsubishi Electric's system regularly monitors the status of EVs connected to or disconnected from the PCS, minimizes power costs by using connected EVs as storage batteries, and refines the charge/discharge schedule every few minutes, thereby minimizing power-cost increases due to any unexpected use of EVs.

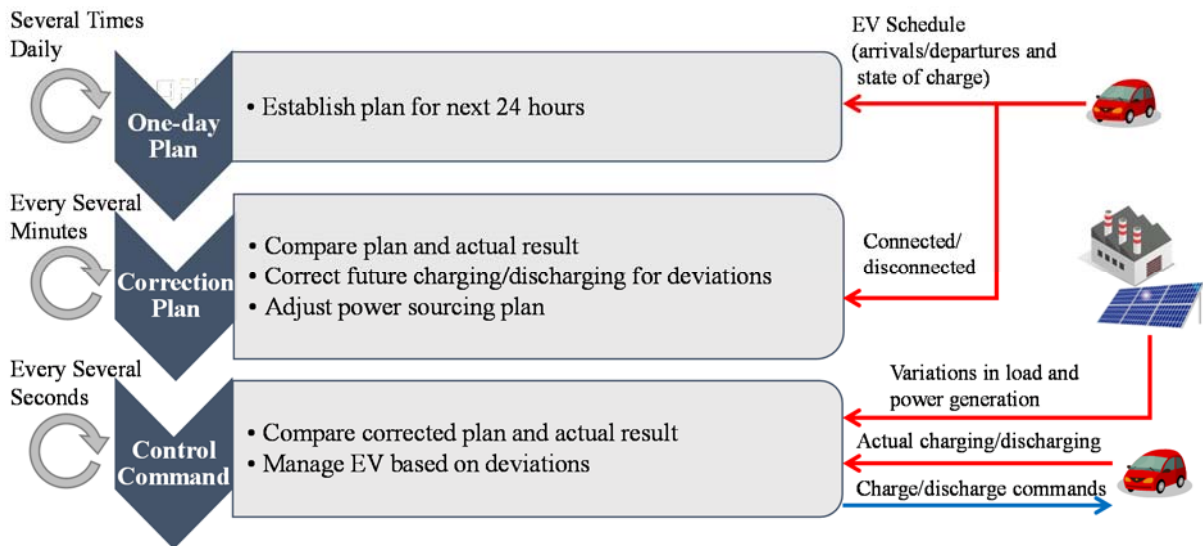

Fig. 3. Multi-step optimization

As shown in the example in Fig. 4, EV1 arrives late at 9:00, preventing it from being discharged as originally scheduled between 8:00 and 9:00. Because the unit price of electricity from the grid is high between 8:00 and 12:00, the discharge amounts from EV3 and EV4 are increased between 8:00 to 9:00 to avoid having to purchase expensive grid power. After EV1 arrives at 9:00, it is discharged beyond the originally scheduled amount, EV3 and EV4 discharges are decreased accordingly, and EV2 which arrives as originally scheduled also discharges, thereby avoiding the use of peak grid power by flexibly adjusting each vehicle's discharge schedule.

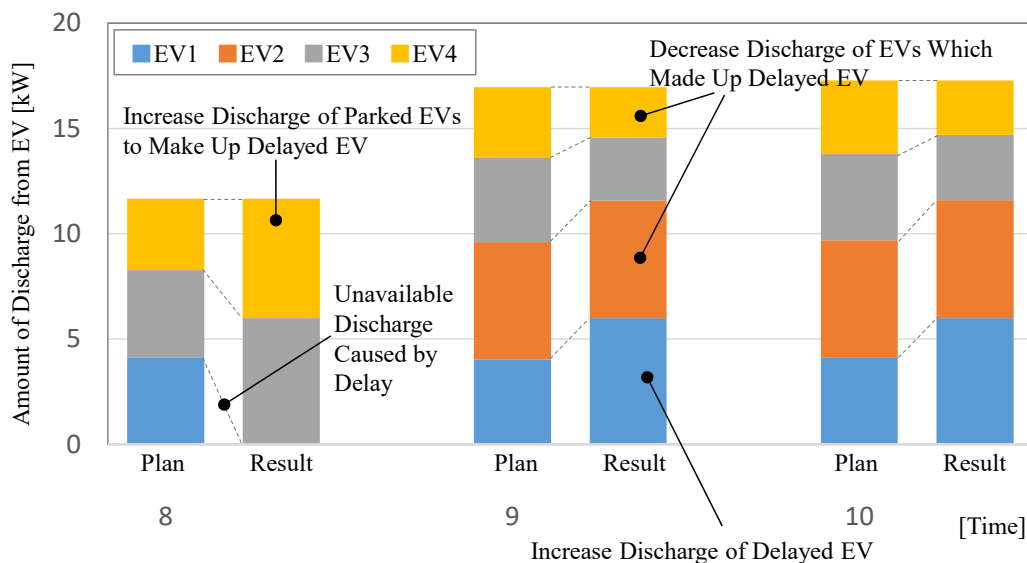

Fig. 4. Adjusting the charge/discharge schedule (example)

###

About Mitsubishi Electric Corporation

With nearly 100 years of experience in providing reliable, high-quality products, Mitsubishi Electric Corporation (TOKYO: 6503) is a recognized world leader in the manufacture, marketing and sales of electrical and electronic equipment used in information processing and communications, space development and satellite communications, consumer electronics, industrial technology, energy, transportation and building equipment. Embracing the spirit of its corporate statement, Changes for the Better, and its environmental statement, Eco Changes, Mitsubishi Electric endeavors to be a global, leading green company, enriching society with technology. The company recorded consolidated group sales of 4,444.4 billion yen (in accordance with IFRS; US\$ 41.9 billion*) in the fiscal year ended March 31, 2018. For more information visit:

www.MitsubishiElectric.com

*At an exchange rate of 106 yen to the US dollar, the rate given by the Tokyo Foreign Exchange Market on March 31, 2018