

mitsubishi

Industrial Sewing Machine

TECHNICAL MANUAL
MECHANICAL VERSION

Electronic Pattern Sewing Machine
Model PLK-E2516R

FOR YOUR SAFETY!





If you are operating the sewing machine for first time, please make sure to read the following instructions for your safety and proper operation.

In this technical manual, the notice **CAUTION** is used to attract your attention to safety. Please keep it in mind whenever you work with the sewing machine.

 **CAUTION** is used as the notice to warn of a possible risk of injuries.

- ★ This technical manual explains how to operate and maintain the sewing machine.
 - ★ All information in this technical manual is subject to change without notice.
 - ★ MITSUBISHI ELECTRIC CORPORATION has all copy rights on this technical manual.
- Reprinting parts or all of this technical manual is not allowed without permission.

Explanations for the warning signs

No.	Warning	Details of warning
1		<p>Cautions for sewing machine operation: Warning to operate the sewing machine without safety guards and to prohibit doing any operation except sewing while the power is turned ON.</p>
2		<p>Caution for a wound on the fingers: Warning to a possible danger to cause a wound on the fingers under the specified operation.</p>
3		<p>Caution for the fingers to be caught in the machine: Warning to a possible danger to be caught the fingers in the machine under the specified operation.</p>
4		<p>Direction of pulley rotation: Indicating the proper rotating direction of the sewing machine pulley.</p>

ENVIRONMENT STANDARD

CAUTION

★For avoiding the sewing machine from the troubles, please do not operate the sewing machine under the following conditions.

- 1)  Temperature and humidity
 - a) During operating : The atmosphere temperature should not exceeded more 35° C (95° F) or less 5° C (41° F).
 - b) During transportation : The atmosphere temperature should not exceeded more 55° C (131° F) or less -10° C (18° F).
 - c) The relative humidity in the atmosphere should not exceeded more 85% or less 45%.

- 2)  Atmosphere for the machine operation
 - a) In the atmosphere filled with dust or corrosive gas.
 - b) In the atmosphere filled with flammable or explosive gas.

- 3)  Power source voltage
 - a) In the place where the power fluctuation exceeds more or less 10% of the fixed power voltage.
 - b) In the place where the power source can not supply enough voltage to keep the motor running.

- 4)  Power source voltage
 - a) In the place where the power fluctuation exceeds more or less 10% of the fixed power voltage.
 - b) In the place where the power source can not supply enough voltage to keep the motor running.

- 5)  Noise
 - a) In the place near a high frequency transmitter or a high frequency welder.
 - b) In the place filled with strong electromagnetic radiation or magnetic field.

CONTENTS

1. STRUCTURE OF THE MACHINE	1
2. SPECIFICATION	2
3. INSTALLATION	3
3-1 Preparation of the table	3
3-2 Preparation of the steel stand	3
3-3 Installation of the motor	3
3-4 Installation of the control box	3
3-5 Connection of the operation panel	3
3-6 Installation of the power switch	4
3-7 Connection of the foot switch	4
3-8 Installation of the oil pan	5
3-9 Installation of the sewing machine head	5
3-10 Putting across the V-belt	7
3-11 Connection of the air tube	8
3-12 Connection of the electric cables	9
3-13 Installation of the belt cover	10
3-14 Installation of the thread stand	11
4. LUBRICATION	12
4-1 Filling the oil tank	12
4-2 Oiling	12
5. PROPER OPERATION	13
5-1 Loading the system software of the control box	13
5-2 Installation of the needle	13
5-3 Threading the upper thread	14
5-4 Winding the bobbin thread	14
5-5 Settling the bobbin	16
5-6 Setting the bobbin case	16
6. PROPER SEWING	17
6-1 Operation of the halt switch	17
6-2 The sewing operation	18
6-3 Adjustment of the thread tension	20
7. STANDARD ADJUSTMENT	21
7-1 Adjustment the needle bar position	21
7-2 Adjust the position between the needle and the shuttle hook	22
7-3 Adjustment of the hook positioner's position	23
7-4 Adjustment of the lubrication for the rotating hook	23
7-5 Adjustment of the presser foot	24
7-5-1 Adjustment of the presser foot position	24
7-5-2 Adjustment of the presser foot lift during the sewing	26
7-5-3 Adjustment of the presser foot timing	27

7-6 Adjustment of the wiper	28
7-7 Adjustment of the bobbin winder	29
7-8 Adjustment of the work holder.....	29
7-8-1 Adjustment of the work holder pressure	29
7-8-2 Changing the work holder	29
7-9 Adjustment of the thread trimmer.....	30
7-9-1 Structure of the thread trimmer mechanism	30
7-9-2 Assembling and readjustment of the thread trimmer mechanism	31
7-9-2.1 Attaching the knife bracket and the knife mounting unit	31
7-9-2.2 Mutual relation among the movable and stationary knife edge.....	31
7-9-2.3 Connection of the knife bracket and the driving crank.....	32
7-9-2.4 Adjustment of the component parts of the knife driving mechanism	32
7-9-2.5 Adjustment of the mounting position of the air cylinder	33
7-9-2.6 Adjustment of the mounting position of the thread trimmer cam	33
7-9-2.7 Adjustment of the knife engagement	35
7-10 Adjustment of the upper thread tension release	36
7-11 Adjustment of the thread tail after the trimming	37
7-12 Cancellation of the trimming function	37
7-13 Adjustment of the thread take up spring swing strike.....	37
7-14 Adjustment of the thread take up spring tension.....	37
7-15 Adjustment of the synchronizer	38
7-16 Adjustment of the mechanical home position.....	38
7-16-1 Shifting the mechanical home position to the X direction	40
7-16-2 Shifting the mechanical home position to the Y direction	40
7-17 Adjustment of the X-Y timing belt tension	41
7-17-1 Adjustment of the X timing belt tension.....	41
7-17-2 Adjustment of the Y timing belt tension.....	41
7-18 Adjustment of the V belt tension.....	42
8. MAINTENANCE	43
8-1 Cleaning	43
8-2 Disposing of oil waste.....	43
9. BAD SEWING CONDITION & ITS CAUSE AND REMEDY	44
APPENDIX.....	47
Ref.1 Table cut-out for PLK-E2516R machine	48
Ref.2 Table and stand	48

1. STRUCTURE OF THE MACHINE

The PLK-E2516R electronic pattern sewing machine is constructed with the following main parts.

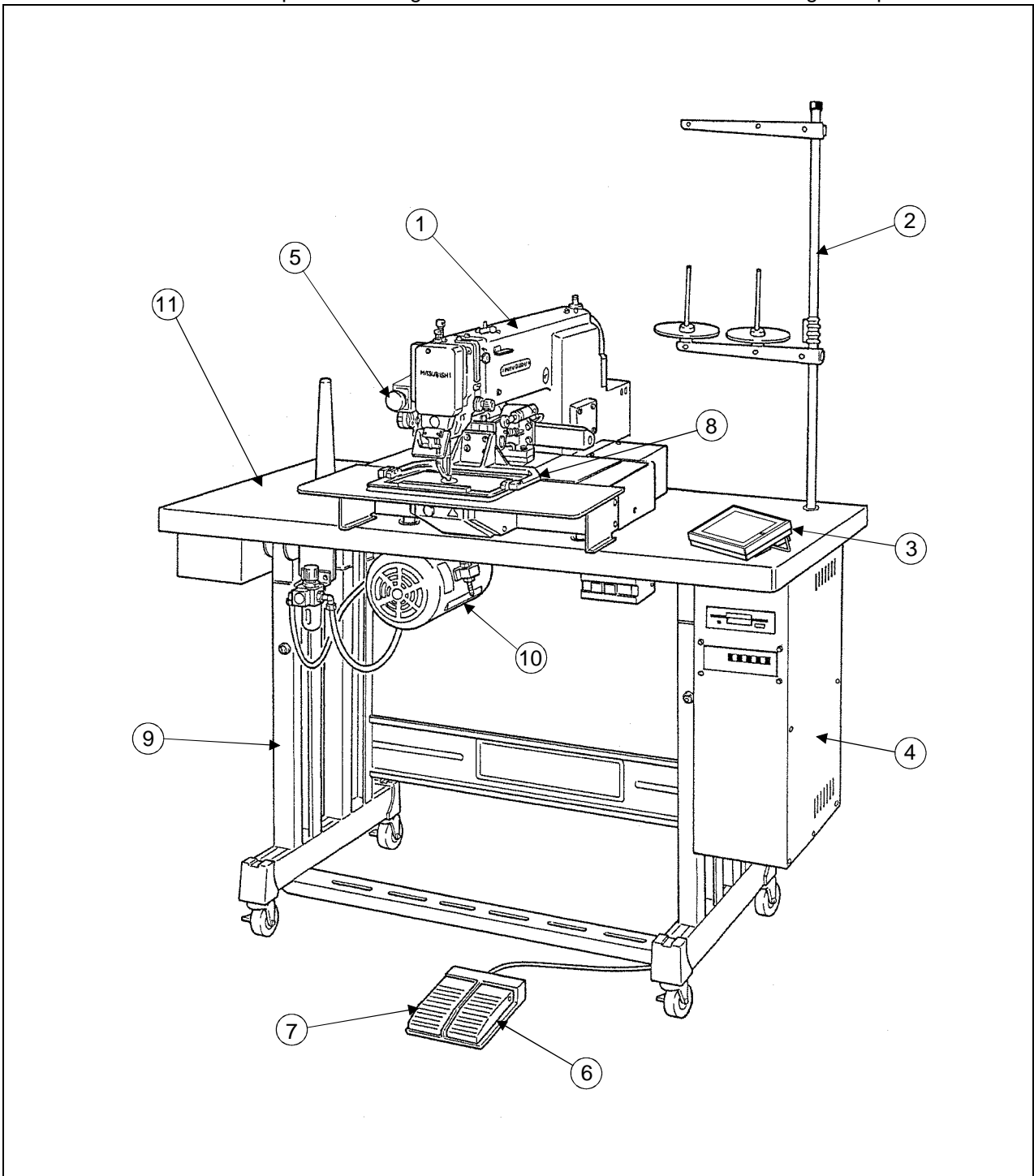

(No.1) Sewing machine head. (No.2) Thread stand. (No.3) Operation panel. (No.4) Control box.
(No.5) Emergency stop switch. (No.6) Work holder foot switch. (No.7) Start foot switch.
(No.8) Work holder. (No.9) Steel stand. (No.10) Limi-servo motor. (No.11) Wooden table top.

2. SPECIFICATIONS

Machine model	: PLK-E2516R
Sewing area	: X Direction (left/right) 250mm Y Direction (forward/backward) 160mm
Maximum sewing speed	: 2,300 S.P.M. (up to 4mm stitch length)
Sewing speed	: 10 steps variable from 200 S.P.M. to 2,300 S.P.M.
Stitch speed	: Adjustable from 0.1mm to 12.7mm by 0.1mm resolution.
Stitch length	: Adjustable from 0.1mm to 12.7mm by 0.1mm resolution.
Stitch type	: Single needle lock stitch.
Needle bar stroke	: 40mm
Thread take up lever stroke	: 72mm
Class of needle	: DP X 17 #18 (standard specification)
Wiper system	: Back to forth wiping system (standard)
Work holder lift *1	: 25mm (max.)
Stepping foot stroke *2	: Variable from 4mm to 10mm (4mm is standard)
Hook	: Large size rotating hook.
Bobbin case	: With non racing spring.
Bobbin	: Large size steel bobbin.
Thread trimmer system	: arc engagement with fixed knife and movable knife
Lubrication system	: Manual oiling and replenishment with the oil braids from the oil tanks.
Lubrication oil*3	: White machining oil.
Machine dimension	: 1, 200mm(W) x 920mm(L) x 1, 170mm(H)
Steel stand	: T-shape steel stand for standing or sitting operation.
Drive source pneumatic pressure	: Primary side 0.5MPa (5kgf/cm ²) Secodary side 0.4MPa (4kgf·cm ²)
Weight	: 180kg (total net weight).

*1 Stepping foot lift means the clearance between the bottom of the stepping foot and the surface of the sliding plate when the sewing machine is stopped.

*2 Stepping foot stroke means the vertical movement of the stepping foot during the sewing operation.

3. INSTALLATION

CAUTION

- ★The machine should be installed by the specialists who have enough experience for the sewing machine installations.
- ★All the necessary electric wiring should be done by electric engineers who are qualified for the electric wiring.
- ★if any damage or fault is found on the machine at the installation, please do not operate until it is repaired.
- ★Please do not operate the sewing machine with excessive modifications from the standard specification.

3-1 Preparation of the table

If the table is not MITSUBISHI original, the thickness of the table is required to have 40mm more. And please refer to the cut out table drawing for your own preparation. The cut out drawing is shown on the last page of this technical manual as APPENDIX drawing.

3-2 Preparation for the steel stand

If the steel stand is not MITSUBISHI original, please refer to the assembling drawing for your own preparation.

If the steel stand is MITSUBISHI original, please assemble the steel stand with the assembling instructions enclosed in the packing.

3-3 Installation of the motor

If the motor is purchased without assembling to the table, the motor has to be installed underneath the table.

Please install the motor with the instructions explained in the paragraph [Installation of the Motor] on the other **CONTROL UNIT** technical manual.

3-4 Installation of the control box

If the control box is purchased without assembling to the table, the control box has to be installed underneath the table.

Please install the control box with the instruction explained in the paragraph [Installation of the control box] on the other **CONTROL UNIT** technical manual.

3-5 Connection of the operation panel

Please connect the operation panel with the instructions of **Operation Panel** Technical manual enclosed in the packing.

3-6 Installation of the power switch

If the power switch is purchased without assembling to the table, the power switch has to be attached with the following procedure.

- 1) Mount the power switch (No.1) with the wood screw (No.2) underneath the table as shown on the figure.
- 2) Fix the electric cords with the staples (No.3) underneath the table.
- 3) Hook up the connector (No.4) of the power switch (No.1) to the connector (No.5) of the control box.
- 4) Attach the power plug (No.7) to another end of the power switch cord (No.6).

NOTE Connect the connector with the instructions in the paragraph [P.10 <Back side view of the Control box>].

3-7 Connection of the foot switch

Connect the foot switch (No.8) to the connector (No.9).

The foot switch is enclosed in the accessory box.

NOTE Connect the connector with the instructions in the paragraph [P.10 <Back side view of the Control box>].

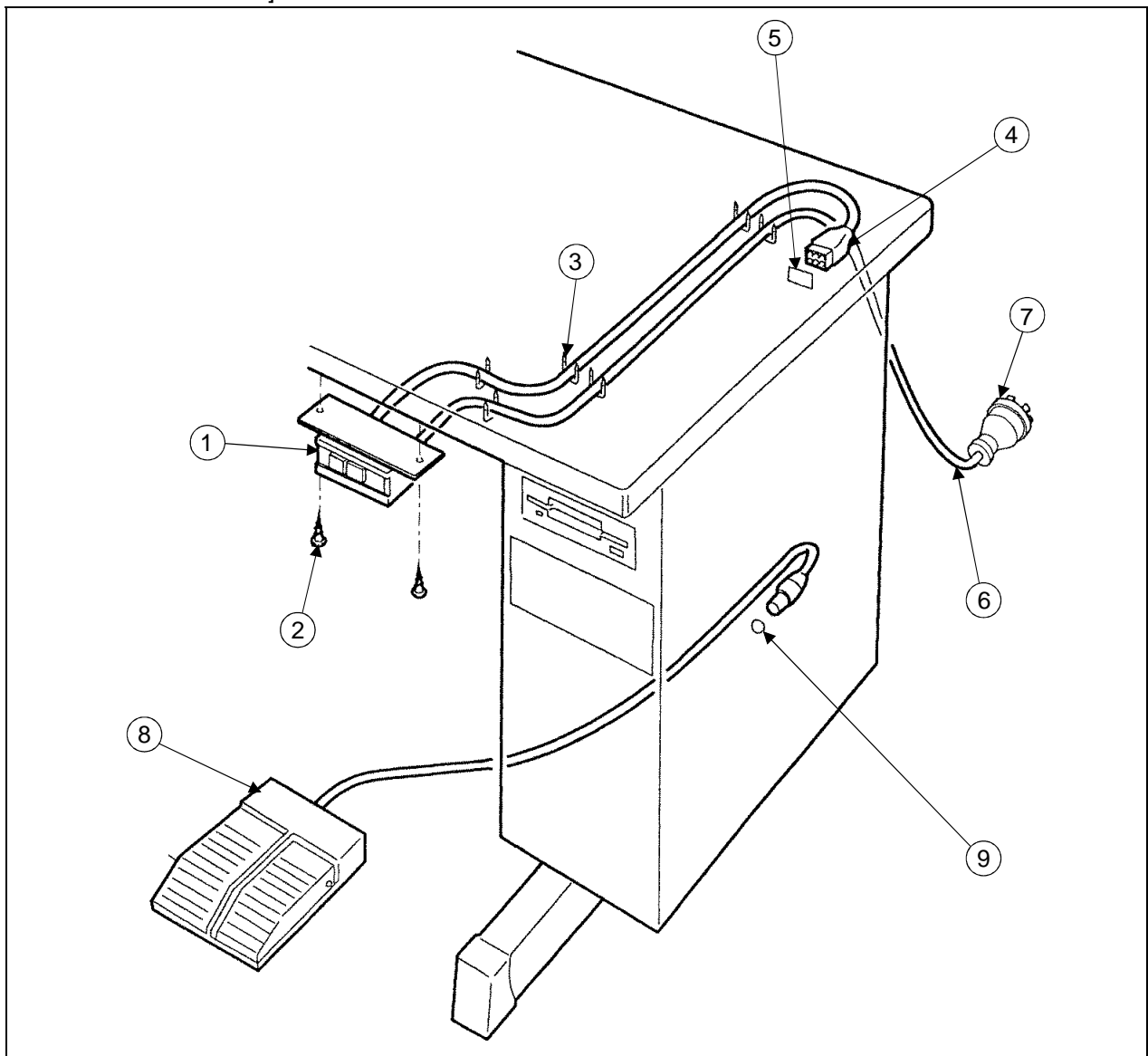

3-8 Installation of the oil pan

- 1) Assemble the oil pan (No.1) and oil bottle (No.2), which are enclosed in the accessory box.
- 2) Insert the oil bottle (No.2) into the table top cut-out hole (No.3), with facing the oil pan end which has much shorter distance from the bottle center front.
- 3) Install the oil pan (No.1) parallel with the table front edge.
- 4) Fix the oil pan (No.1) at its four corners on the table top with four staples (No.4) enclosed in the accessory box.

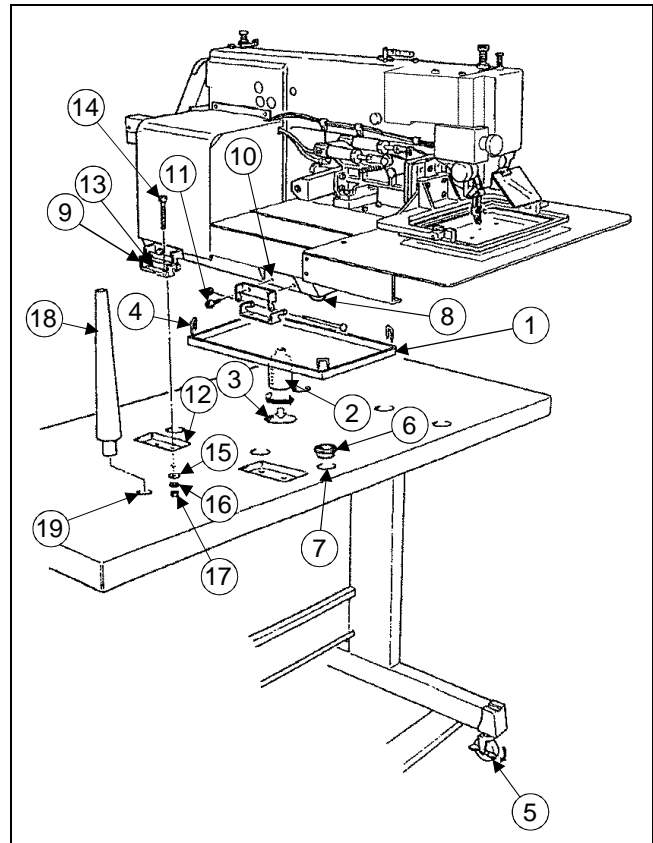

3-9 Installation of the sewing machine head

! CAUTION

★For the safety, please make sure to carry the sewing machine head by two people at least.

- 1) Make sure to hold the machine table with the caster stopper (No.5).
- 2) Fit the rubber cushion pads (No.6) into the each hole (No.7) on the table top. The rubber cushion pads (No.6) are enclosed in the accessory box.
- 3) Put the sewing machine head on the table top and set the each leg (No.8) to the each rubber cushion pad (No.6).
- 4) Attach two hinges (No.9) temporarily, make the set screws (No.11) fastening with the thread holes (No.10) light, on the left side surface of the machine bed with the hexagonal socket head set screw (No.11).
At this time, take notice of the E-shaped snap ring must be come to the front.
- 5) Fit the screw holes (No.13) of the hinges (no.9) to the bolt setting holes (No.12) on the table top then, pass the bolt (No.14) through these holes and fasten the bolt (No.14) to fix the hinges (No.9) with the flat washers (No.15), the spring washers (No.16) and the nuts (No.17).
- 6) Fasten firmly the hexagonal socket head set screw (No.11) which set the hinges (No.9) temporarily at above procedure 4) then, fix the hinges (No.9) perfectly.
- 7) Insert the head rest (no.18) into the hole (No.19) on the table top.

CAUTION

★Please pay attention to the forward and backward supporting portion when lift the sewing machine head.

- 1) The forward supporting portion : Never lift the sewing machine head with the sliding plate (no.21). Always lift the sewing machine with the left and right grips (No.20).

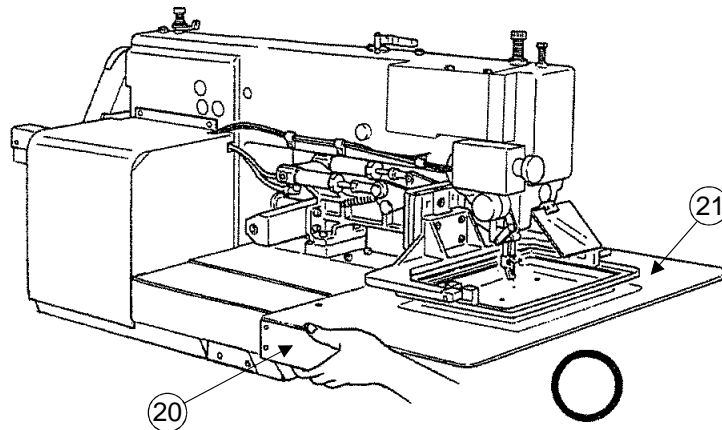

- 2) The backward supporting portion : Support the base of the rear section of the arm (No.22) that is jutting out and lift up while holding nearest the connecting section of the arm's jutting section.

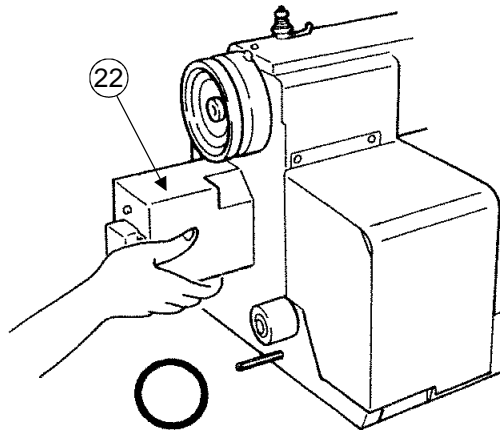

CAUTION

- ★For safety purposes, tilting or raising of the sewing must always be carried out by two or more workers.
Apply a stopper on the leg casters to prevent the table from moving, and then securely support the bed base and the sewing machine head.
- ★Hold the work holder frame to prevent it from dropping down when tilting the sewing machine.

- 1) Tilt the sewing machine head to the left, and hold it with the head rest (No.1).
- 2) Put the V-belt (No.2) across the sewing machine pulley (No.3) and the motor pulley (No.4) with passing it through the slit on the table top.
The V-belt (No.2) is enclosed in the accessory box.
- 3) Raise the tilted sewing machine head to the original position.
- 4) Push the center portion of V-belt by the finger with the pressure of about 1 kg.
If the V-belt tension is proper, it should be yielded about 10mm.
If the V-belt tension is not proper, please adjust it with changing the motor setting position with loosening the nuts (No.5).
Please make sure to fasten the nuts (No.5) firmly after the adjustment.
- 5) Mount the motor's pulley cover (No.6), and tighten it with two set screw (No.7).

NOTE The V-belt becomes loose after a long period machine running.

If the looseness is recognized definitely, firstly turn the power OFF then, adjust the V-belt tension again as the above procedure 4).

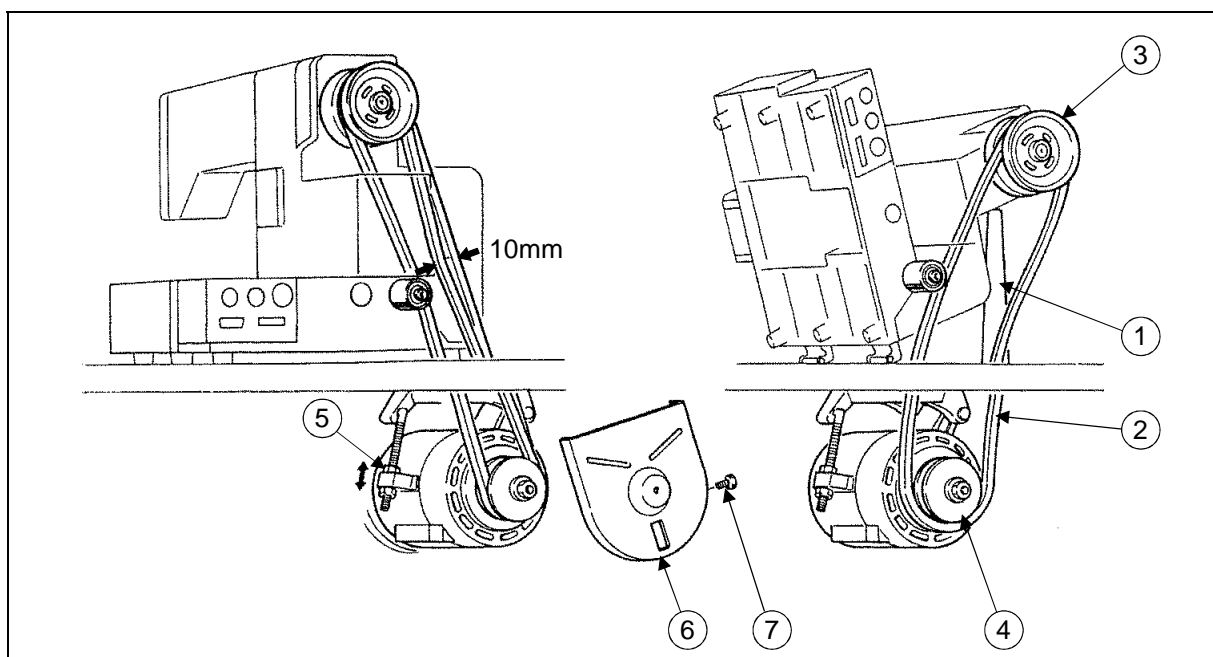

3-11 Connection of the air tube

- 1) Remove the stepping motor cover (No.1).
- 2) Attach the air presser regulator assembly (No.2) underneath the table with the wood screws (No.3).
The prepared holes are provided for the wood screws on the rear surface of the table.
- 3) Cut the part of size $\phi 8$ air tube (No.4) enclosed in the accessory box into about 1 meter length then, insert one end of this air tube into the manifold air fitting (No.6). The manifold is jointed with the magnet valves (No.5) and located at the left side surface of the sewing machine head.
Beside, pass the other end of the air tube (No.4) through the cut out hole of the table top then, insert it into the air outlet fitting (No.7) of the cut out hole of the table top then, insert it into the air outlet fitting (No.7) of the air presser regulator (No.2).
- 4) Insert the one end of the resting air tube (No.4) into the intake air fitting (No.8) of the air coupling to be adopted with the air supply source provided in your factory.
One of the air couplings is enclosed in the accessory box.

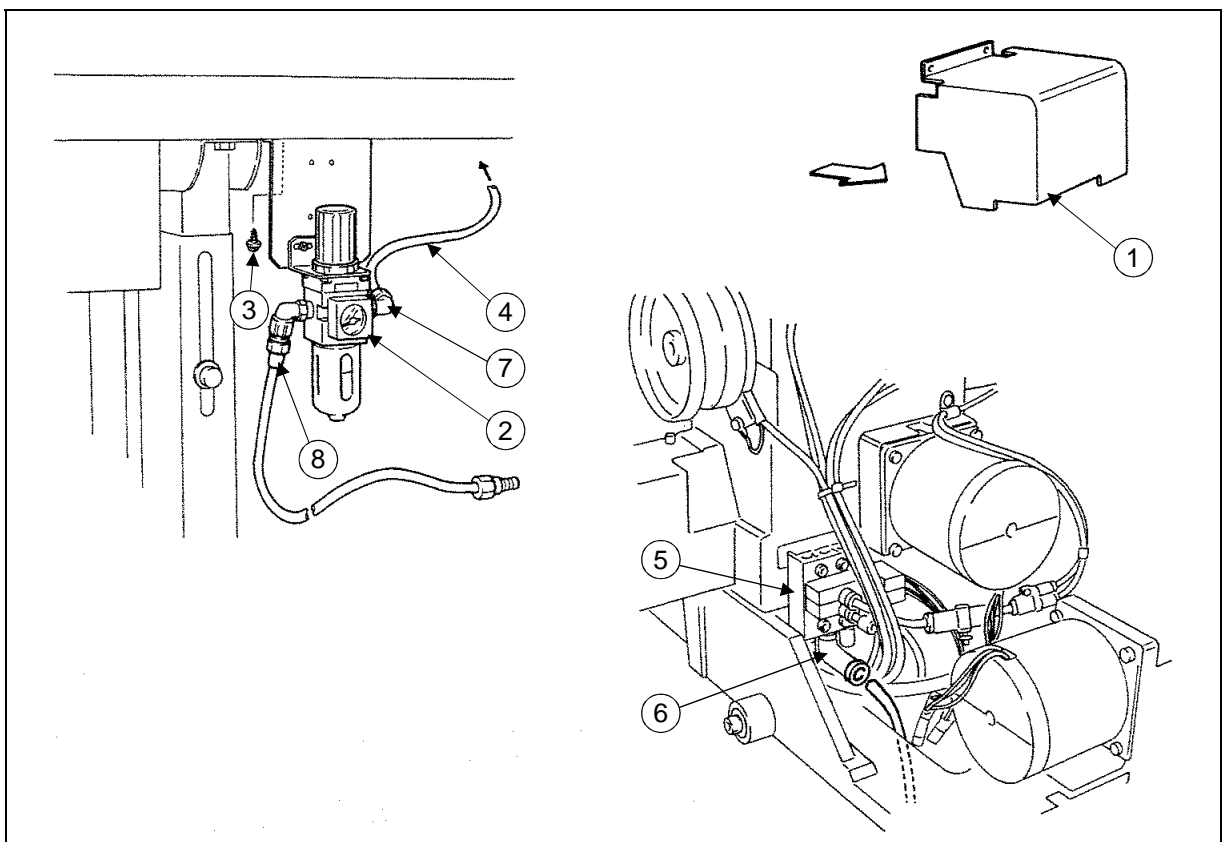

3-12 Connection of the electric cables

- 1) Connect the white color cable (No.1) and the black color cable (No.2) across the printed circuit board unit connectors (No.4) on the sewing machine head (No.3) rear face and the connectors (No.5) on the control box. At this time, bundle the white color cable (No.1) and the black color cable (No.2) with the nylon clip (No.6) and fix them to the sewing machine head (No.3) rear face with the set screw (No.7). All these parts are enclosed in the accessory box.
- 2) Remove the stepping motor cover (No.8) from the sewing machine head (No.3).
- 3) Pass upward the cable (No.9) which is attached the two connectors at the end through the cut-out hole (No.16) on the table top then, connect it to the cable (no.10) and (No.11) extended from X and Y stepping motor. At this time, fix this cable with the nylon clip (No.13) provided on the sewing machine head. And also, connect the other end of the cable (No.9) to the connector (No.12) on the control box. The cable (No.9) is enclosed in the accessory box.
- 4) Pass downward the another cable (No.15) which is extended from the sewing machine head and attached 4 pin connector through the cut-out (No.16) on the table top then, connect it to the cable (No.18) extended from the motor (No.17).
- 5) Connect the last cable (No.19) to the another extended cable (No.20) from the motor then, book up the other end of the cable (No.19) to the connector (No.21) on the control box. The cable (No.19) is also enclosed in the accessory box.
- 6) Attach the two binder (No.22) underneath the table with the wood screws (No.23) then, bundle and fix all the connected cables with the binders (No.22) and the staples (No.24). The binders (No.22), the wood screws (No.23) and the staples (No.24) are enclosed in the accessory box.

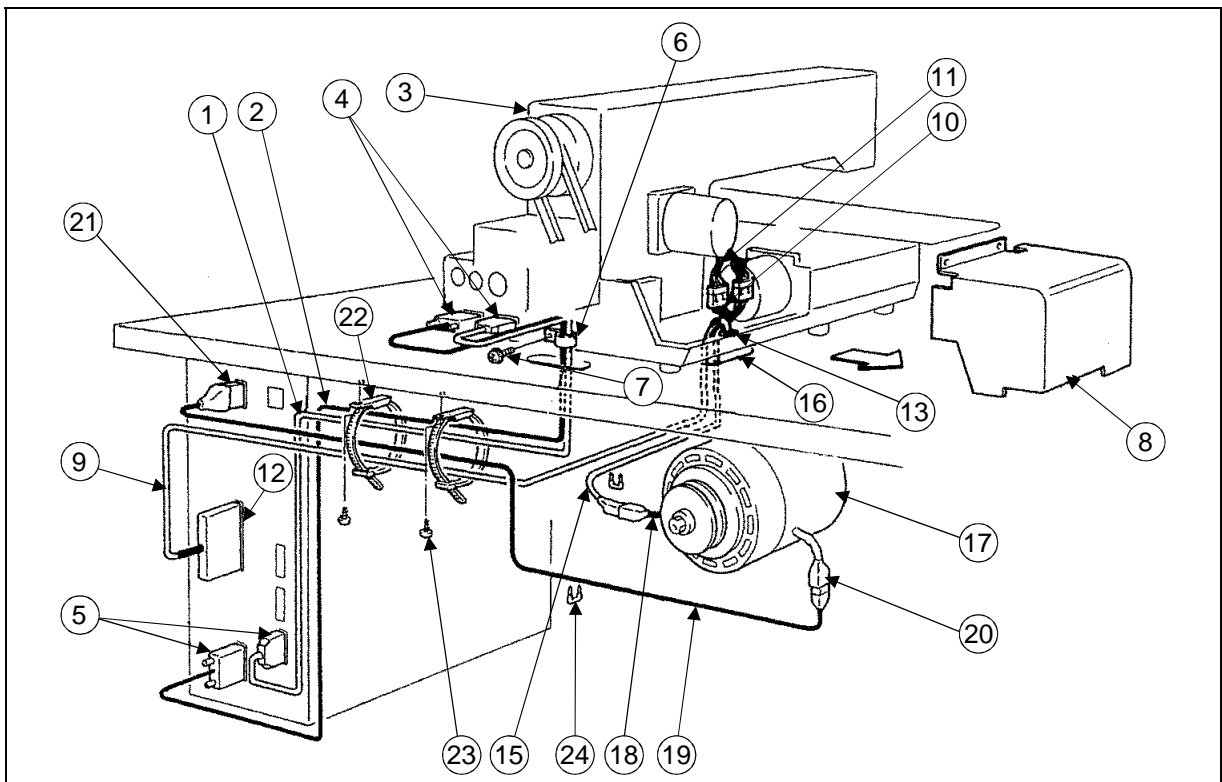

<Back side view of the Control box>

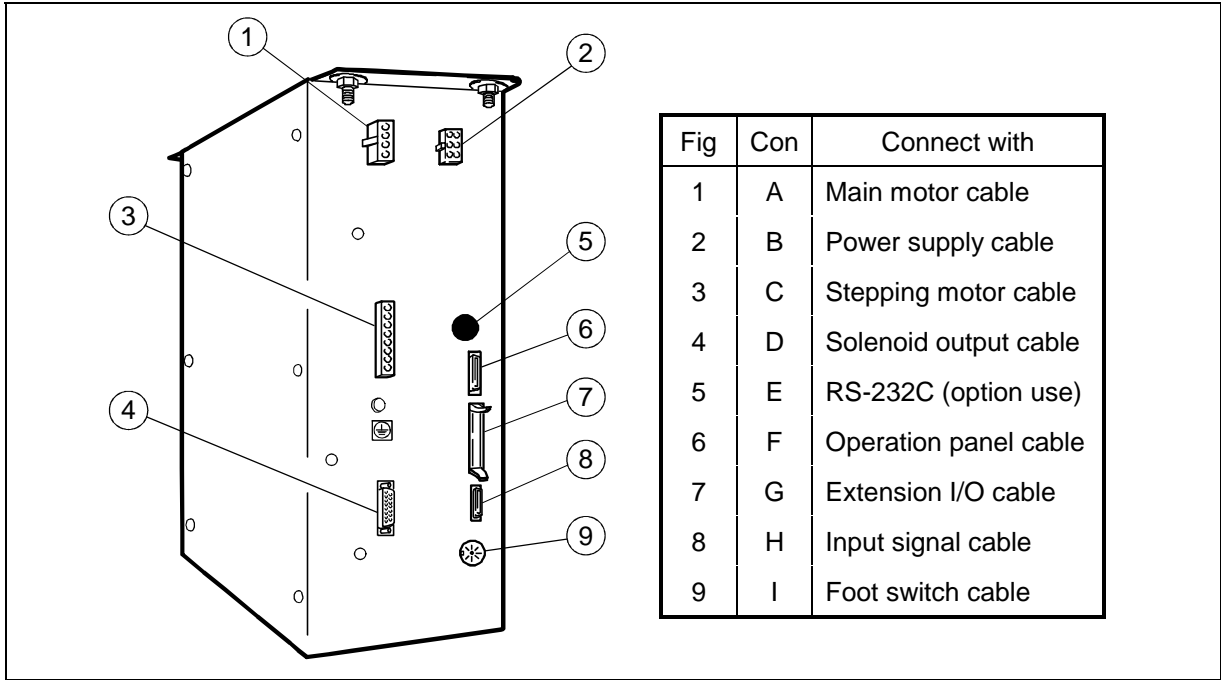

3-13 Installation of the belt cover

Attach the special bolt (No.1) enclosed in the accessories box to the side of the sewing machine bed. Then, remove the large belt cover (No.2) and small belt cover (No.3) from the accessories box, and mount them on the sewing machine head and table with the set screws (No.4 and 5), washers and wood screws (No.6).

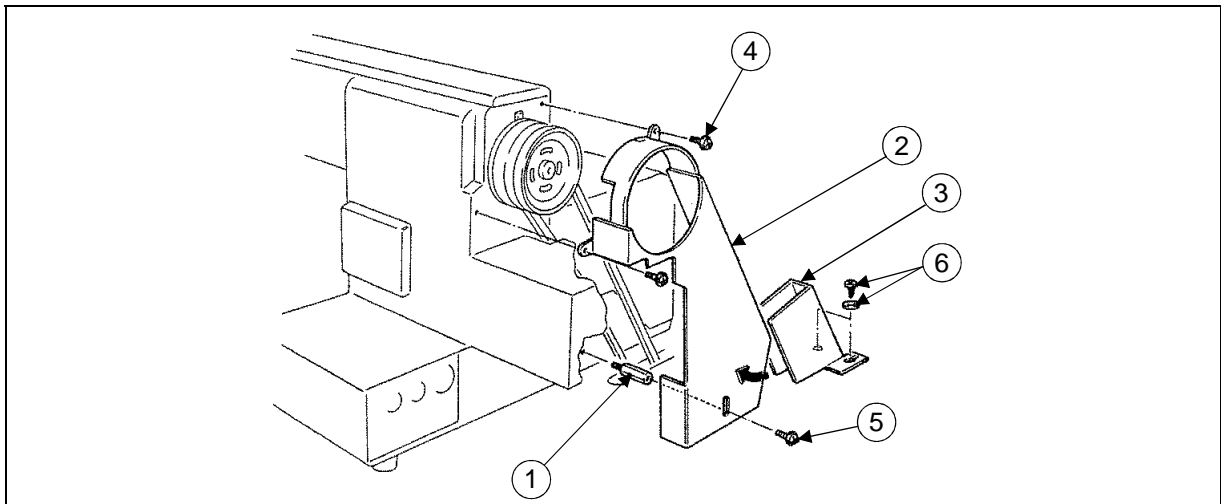

3-14 Installation of the thread stand

- 1) Assemble the thread stand with the instructions enclosed in the packing.
- 2) Fit the thread stand (No.1) in the thread stand hole on the table top.
- 3) Fix the thread stand (No.1) firmly from the rear side of the table with tightening the nut (No.3) and the washers (No.2).

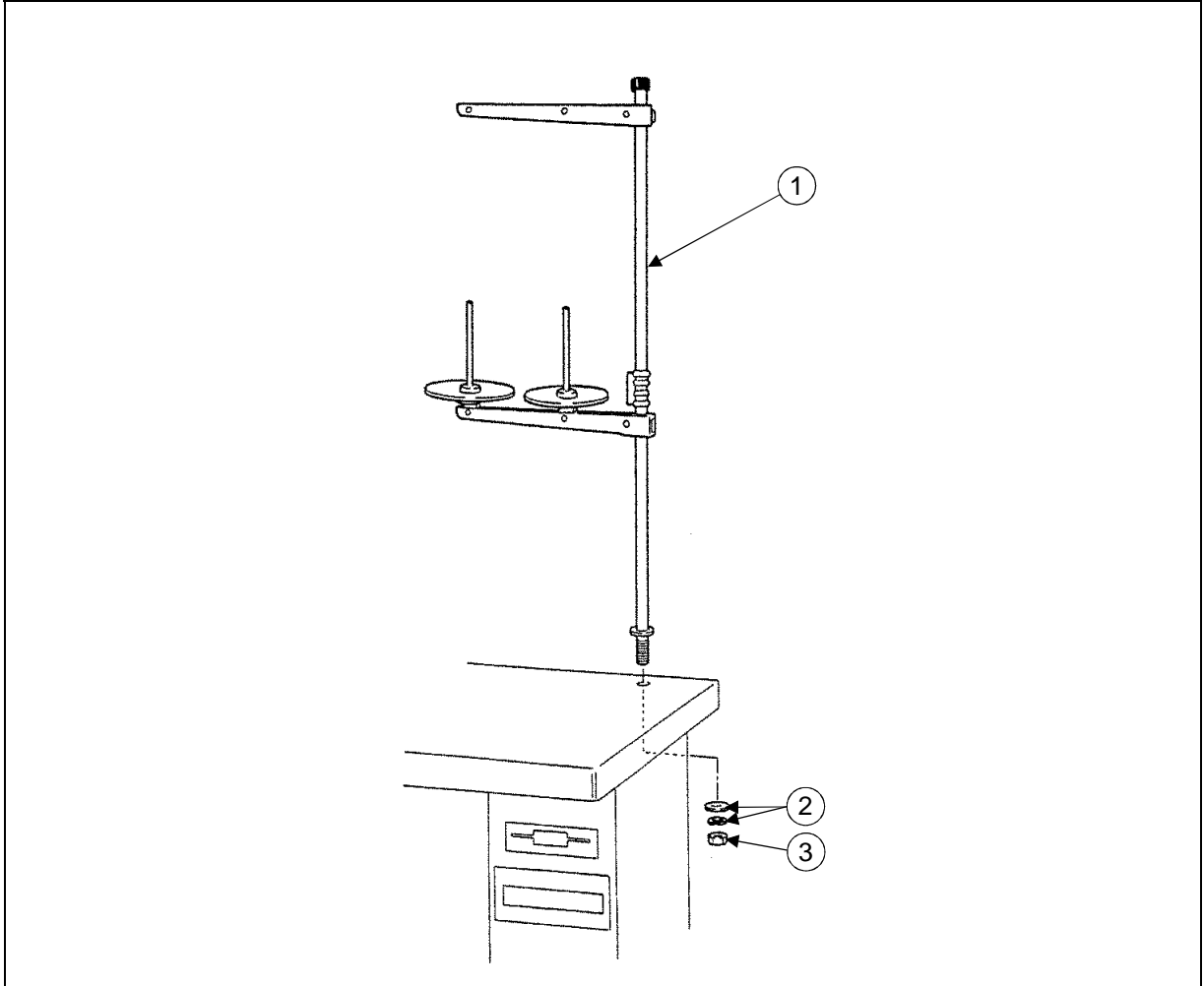

4. LUBRICATION

! CAUTION

- ★ Please make sure to turn the power switch OFF before oiling.
- ★ Please make sure to put some oil before starting the operation of the brand new machine or when the sewing machine is resumed the operation after a long interval.

NOTE Please use high quality white machining oil.

4-1 Filling the oil tank

Pour the oil through the oil hole (No.1) to the oil tank (No.2) on the machine arm. Pour the oil through the oil hole (No.3) to the oil tank (No.4) on the machine bed.

Please fill with the oil over level mark (No.5) of the oil tank.

4-2 Oiling

Put some oil to the red marked oil holes (No.6 to 12).

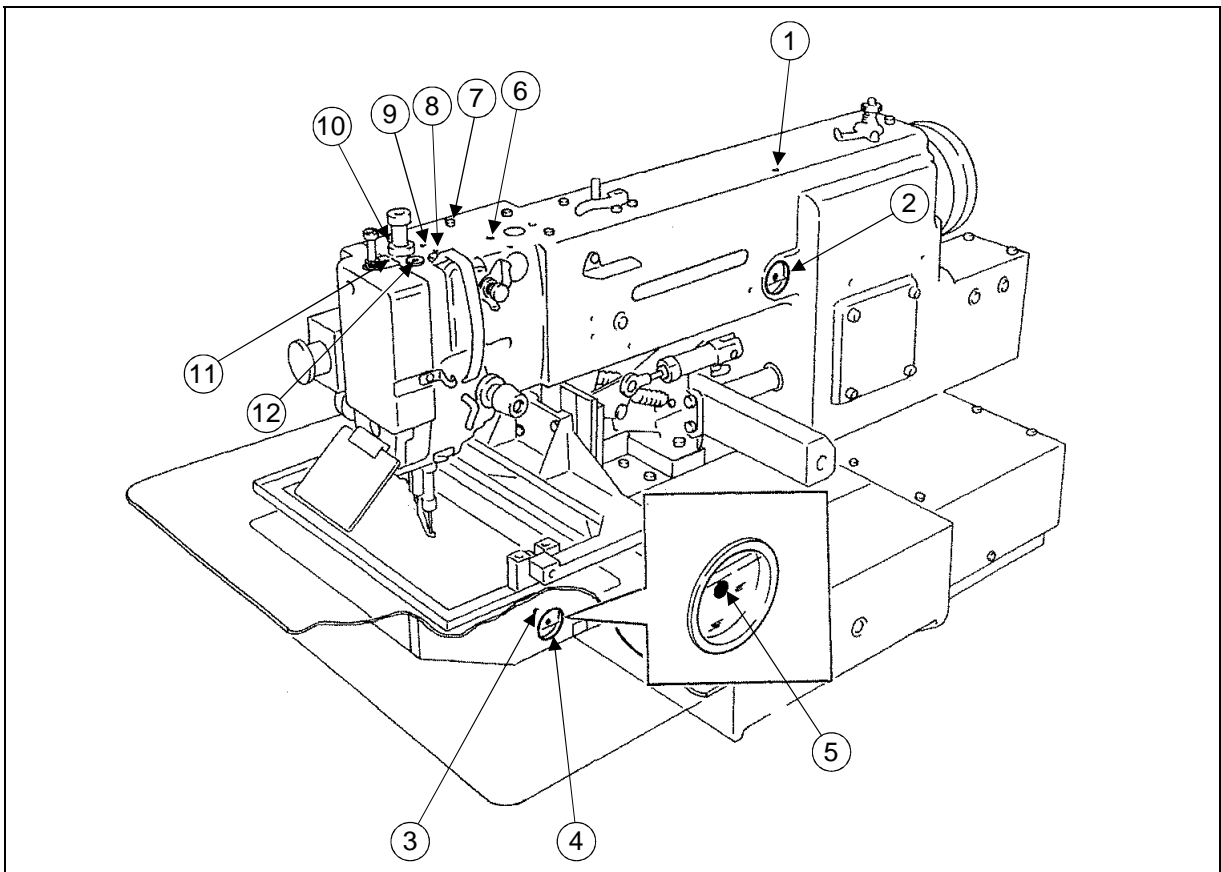

5. PROPER OPERATION

5-1 Loading the system software to the control box

When the brand new machine is operated first time or when the control box is adjusted for the repairing, the system software has to be loaded to the control box.

For this loading, please take the following procedure.

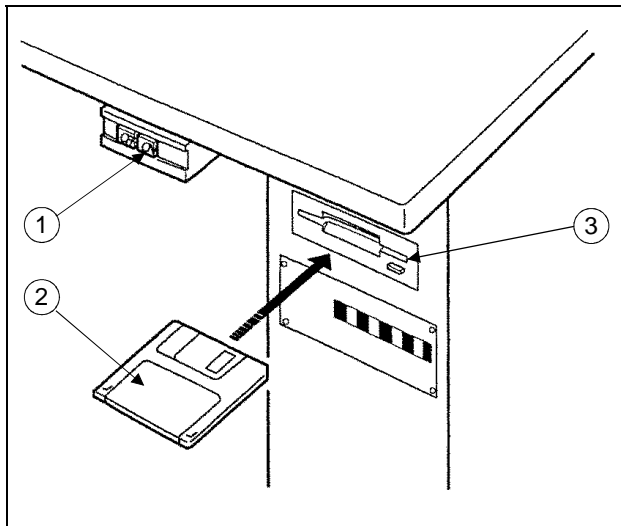

- 1) Insert the system floppy disc printed [F1] (no.2) into the disc drive (No.3) of the control box. The system floppy discs are enclosed in the accessory box.
- 2) While holding down the **[F]** key on the setting panel of the control box, turn the power switch (No.1) ON.
- 3) Load the system software with following the instructions [System installation method] on the technical manual **[CONTROL UNIT]**.
- 4) After loading the system software, keep the system floppy disks with in care.

5-2 Installation of the needle

! CAUTION

- ★Please make sure to turn the power switch OFF before installing or replacing the needle.
- ★Please pay attention for the fingers not to be wounded by the needlepoint.

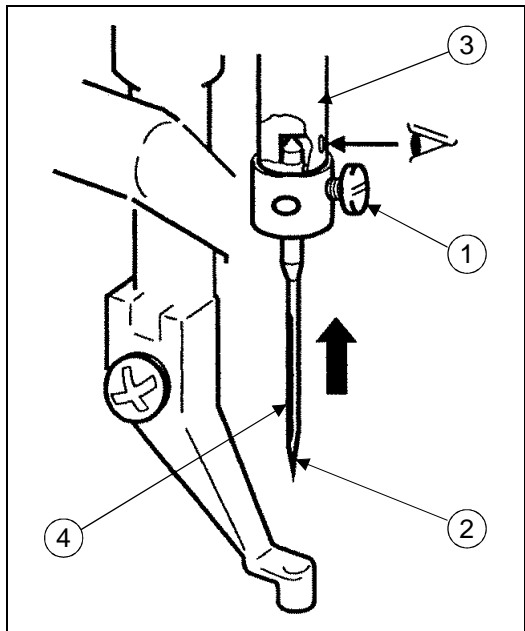

- 1) Loosen the needle set screw (no.1) then, insert the end of the hole of the needle bar (No.3).
- 2) Fasten the set screw (No.1) with facing the needle groove (No.4) to the front.

5-3 Threading the upper thread

CAUTION

★Please make sure to turn the power switch OFF before threading the upper thread.

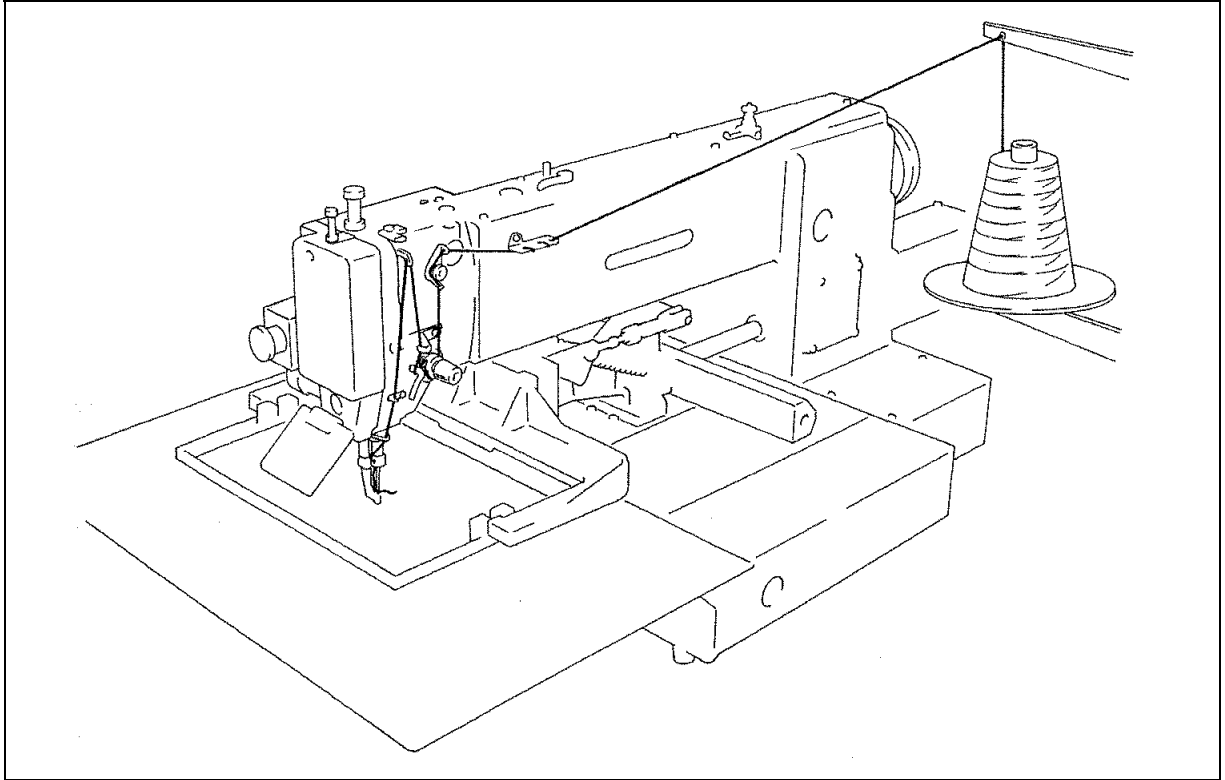

Please thread the upper thread with referring to the below figures.





5-4 Winding the bobbin thread

CAUTION

★Please make sure to pull the upper thread out of the needle before winding the bobbin thread.

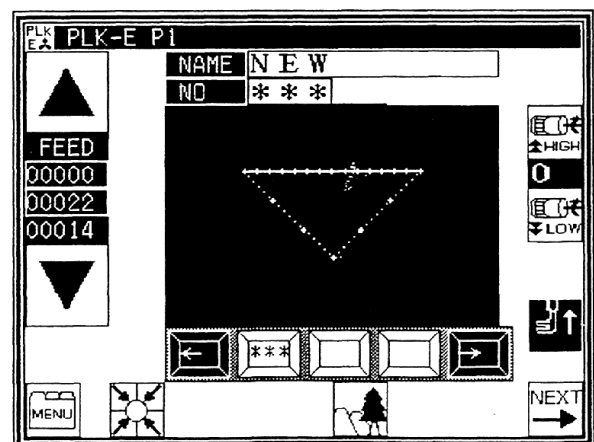
- 1) Turn the power switch ON.
- 2) Press the  key on the operation panel to enter the second operation window.
- 3) Pass through the thread from the thread stand (No.1) as shown on the below figure then, wind the thread to the empty bobbin (No.2) in the arrow mark "a" direction couple times and insert the bobbin (No.3) into the bobbin winder (No.4).
- 4) Push the adjust lever (No.6) in the arrow mark "b" direction.
- 5) Step on the black color foot switch (No.5) then work holder goes down.
- 6) Press the  key, then work holder moves to home position.



7) Press  key on the operation panel.

Then presser foot goes down automatically, and wind mode window will be appeared.

8) Step on the black color foot switch (No.5) again to make work holder down.

9) Step on the gray color start foot switch (No.6).

The thread is kept winding to the bobbin (No.2) while the gray color start switch is stepping on.

10) When the bobbin becomes full of the thread, the adjust lever (No.4) is returned to the original position.

11) Stop to step the gray foot switch and press the



key to exit winding mode, and press the  key, to back to the standard operation windows will be appeared.

12) To wind the bobbin thread during the sewing operation, carry out above 3) and 4) procedure then, the bobbin winding is performed automatically.

13) Regarding the adjustment for the bobbin thread winding volume, please refer to the instructions in the paragraph [7-8 Adjustment of the bobbin winder] in the following page.

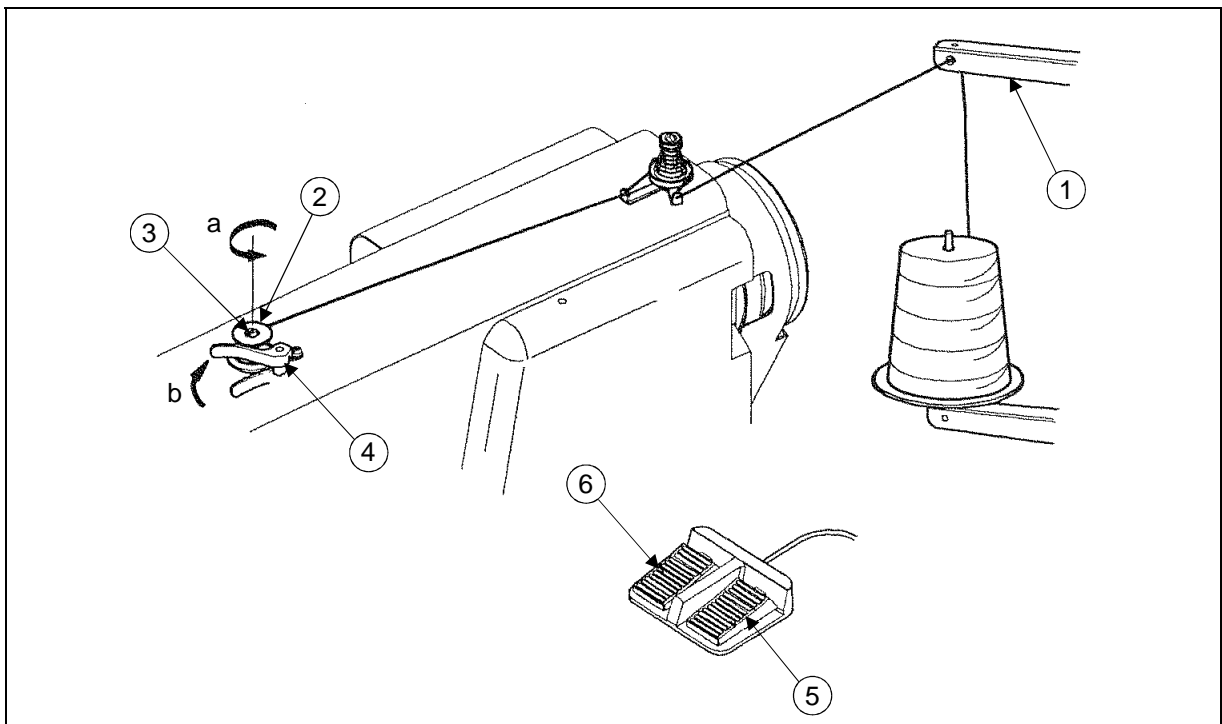
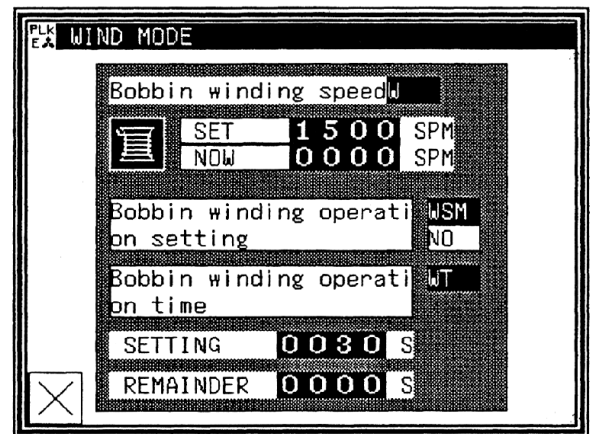
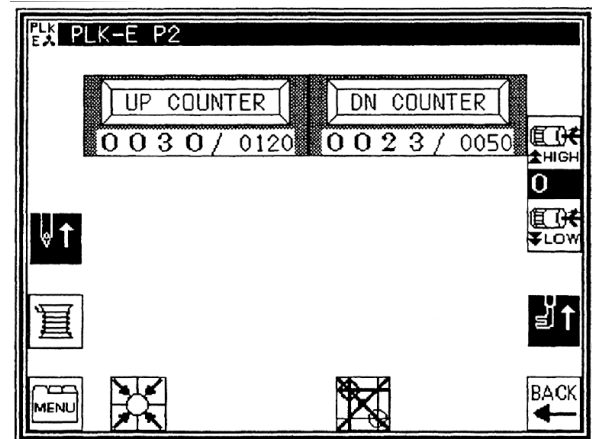

5-5 Setting the bobbin

- 1) Set the bobbin (No.2) into the bobbin case (No.1).
- 2) Pull the bobbin thread (No.3) into the slit (No.4) and pass the through the thread hole (No.5).

At this time, pull the bobbin thread (No.3) then, check with the bobbin (No.2) if it is rotated to the arrow direction. If it is not, set the bobbin (No.2) into the bobbin case (No.1) over again to get the proper rotation.

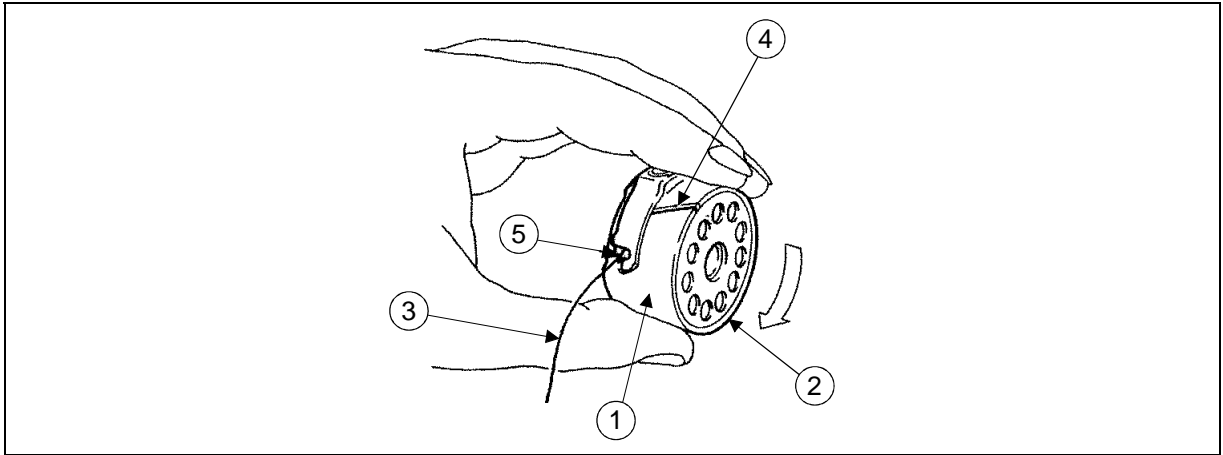

5-6 Setting the bobbin case

- 1) Set the needle bar to its highest position then, open the cylinder cover (No.1).
- 2) Open the bobbin case latch lever (No.2) fully then, fit it securely in the inner hook (No.3).

NOTE Please pull the bobbin thread about 50mm out of the thread hole (No.4) of the bobbin case.

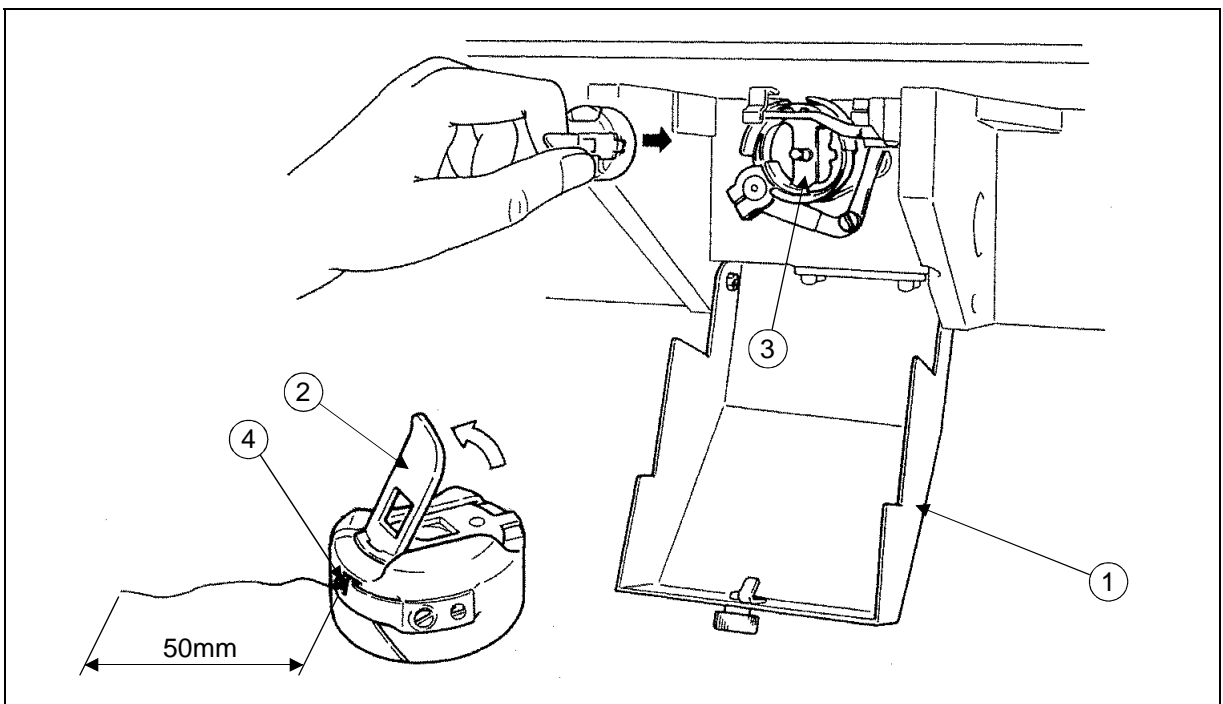

6. PROPER SEWING

6-1 Operation of the halt switch

If an incident such as a thread breakage, needle breakage and any other incidents are happened during the sewing operation, please hit immediately the halt switch. The sewing machine running is stopped instantly.

CAUTION

- ★ Before start the sewing operation, please make sure the location of the halt switch and keep it in mind the function and how to use it.
- ★ Please keep away the hands and the face from the needle during the sewing operation.

- 1) Press the HALT switch (No.1). All operations will stop, and the sewing machine will stop at the needle UP state without trimming the thread.
- 2) Remove the cause of the abnormality.
- 3) To continue sewing, turn the HALT switch (No.1) to the right, and unlock the switch.
Next, when the start switch (No.3) (gray foot switch) is pressed again, the operation will resume from the halted position.
- 4) To cancel sewing, turn the HALT switch (No.1) to the right, and unlock the switch.
Then, press the  key on the operation panel (No.2).
The work holder (No.4) will return to the home position from the stopped position and will stop.

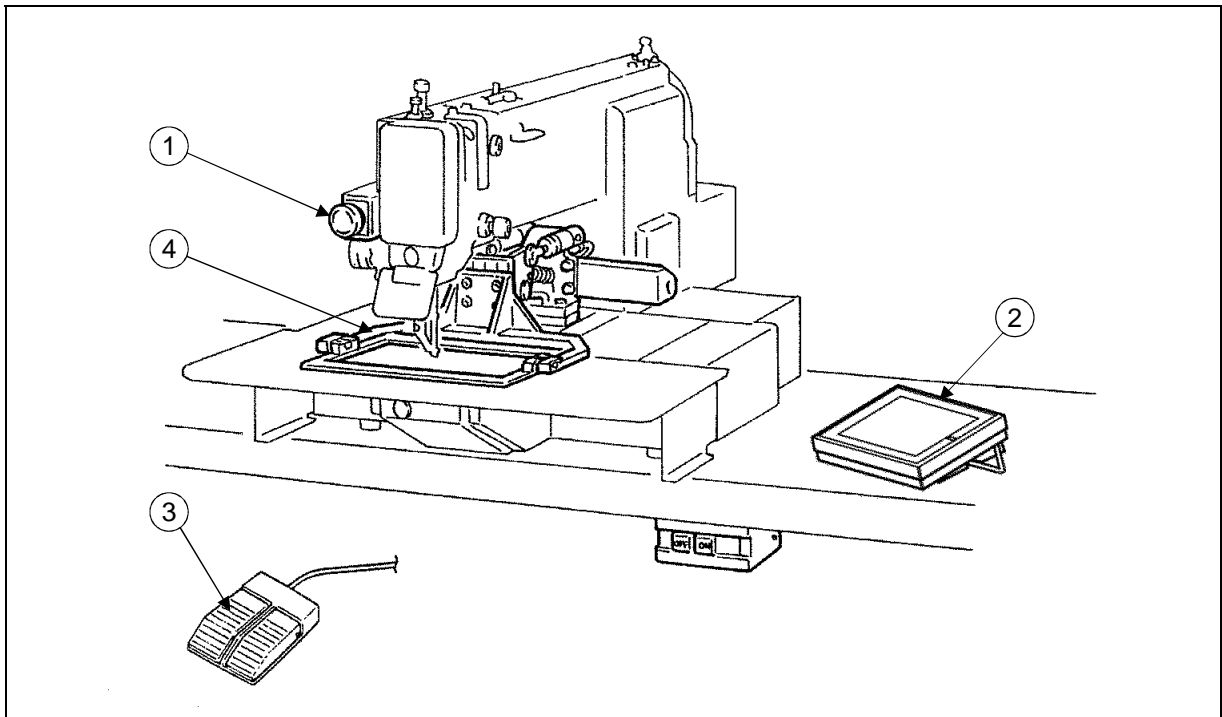

! CAUTION

- ★ Depending on the shape of the work holder, the collision may be happened with the work holder (No.5) and the presser foot (No.6) while the work holder is on the way back to the home position.
- ★ For avoidance of this accident, before starting the sewing operation, program the work holder returning home with the operation panel of the control box to trace the setting, refer to the [Wiper Setting] in the [PROGRAM MODE] on the operation panel.

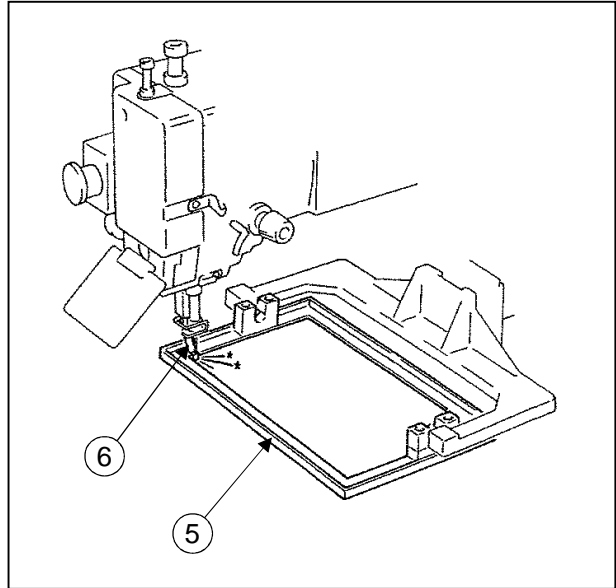



6-2 The sewing operation

! CAUTION



- ★ It is very dangerous to operate the sewing machine without the safety guards (Eye guard, Belt cover, Finger guard etc.). Please make sure to always operate the sewing machine with the safety guards.
- ★ Please do not put unnecessary articles except for the sewing operation on the tabletop.
- ★ Please keep the hands and the face away from the needle.

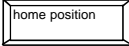

1) Turn the power switch (No.1) ON.

NOTE The collision may be happened with the work holder and presser foot depending on the work holder shape when the work holder is moved to original position.

- a) Press the  key at the normal mode condition, then MENU
Press the  key.
- b) Press the  key.
- c) And the press the [HPF]key and select the [ON] key.



2) Program or select the required sewing pattern by selecting following icon.

Programming.....  >> 

Selecting pattern  >> 

The sewing pattern programming or selecting can be performed with the operation panel.

For the details, please refer to the instructions on the technical manual **Operation Panel**.

3) Set the sewing speed by selecting  or  icon.

4) Insert the sewing material under the work holder (No.3) then, step on the black color foot switch (No.4).The work holder comes down to press the sewing material.

NOTE If the sewing material has to be reset, step the black color foot switch (No.4) again then, the work holder (No.3) goes up to release the sewing material.

5) Step on the gray color start switch (No.5). The sewing machine starts the sewing.

6) After finished the sewing, the work holder is lifted automatically then, the sewing material is released.

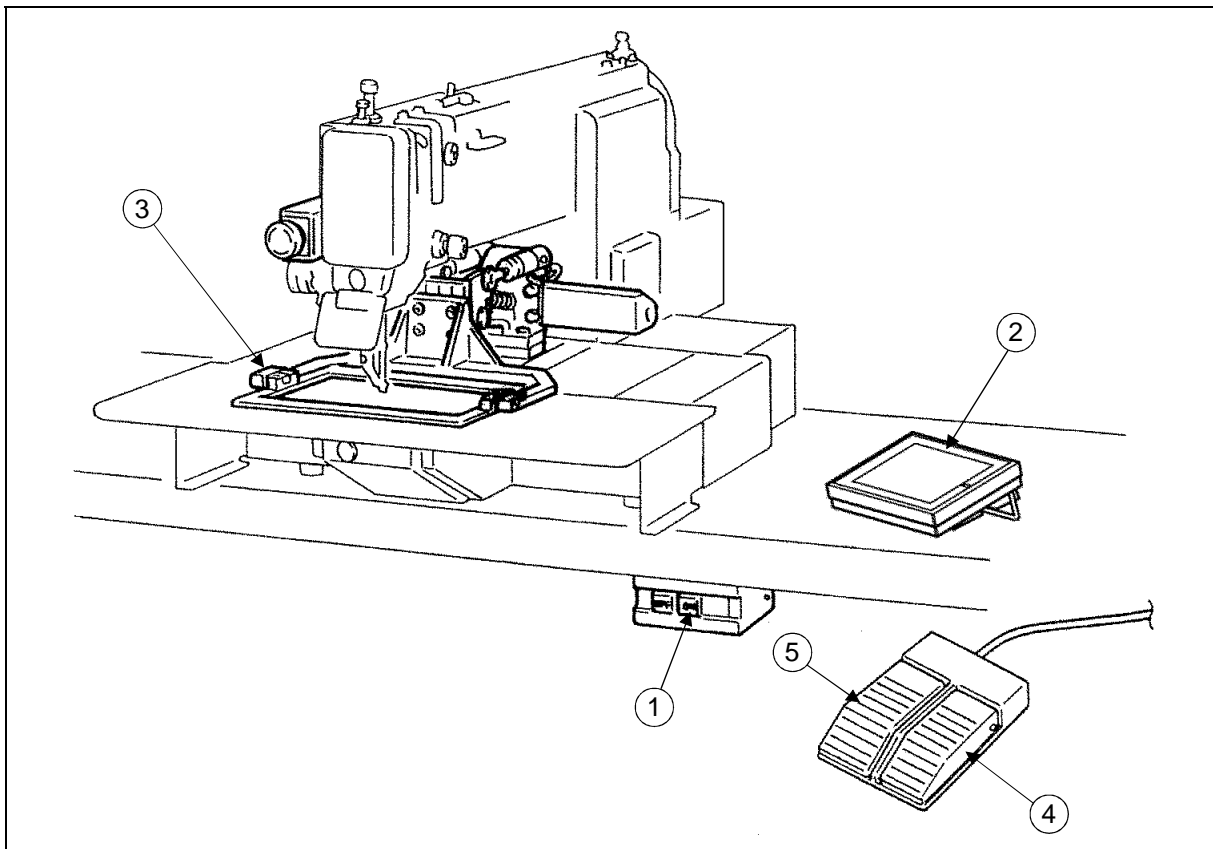

6-3 Adjustment of the thread tension

The thread tension between the upper and bottom thread should be balanced in the best condition.

When the upper thread tension is well balanced with bobbin thread tension, both threads are interlocked along the centerline of fabric layers as shown in the below figures.

NOTE Normally weaker bobbin thread tension brings better sewing quality.

So it is prefer to set bobbin thread tension first and then set upper thread tension.

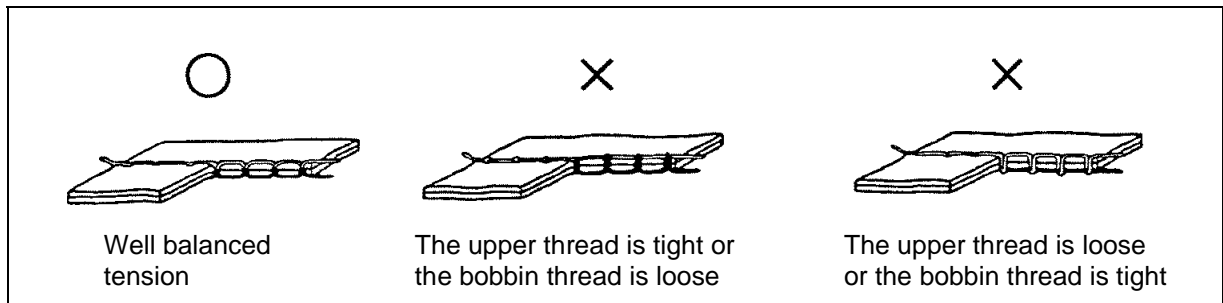

1) Bobbin thread tension

Adjust the bobbin thread tension with the thread tension adjusting screw (No.2) on the bobbin case (No.1). The thread tension becomes loose if turn the thread tension adjusting screw (No.2) to the counterclockwise, and the thread tension becomes tight if turn it to the clockwise.

2) Upper thread tension

Adjust the upper thread tension based on the bobbin thread tension.

For this adjustment, turn the thread tension adjusting nut (No.3). The upper thread tension becomes tight if turn the thread tension adjusting nut (No.3) to the clockwise, and the upper thread tension becomes loose if turns it to the counterclockwise.

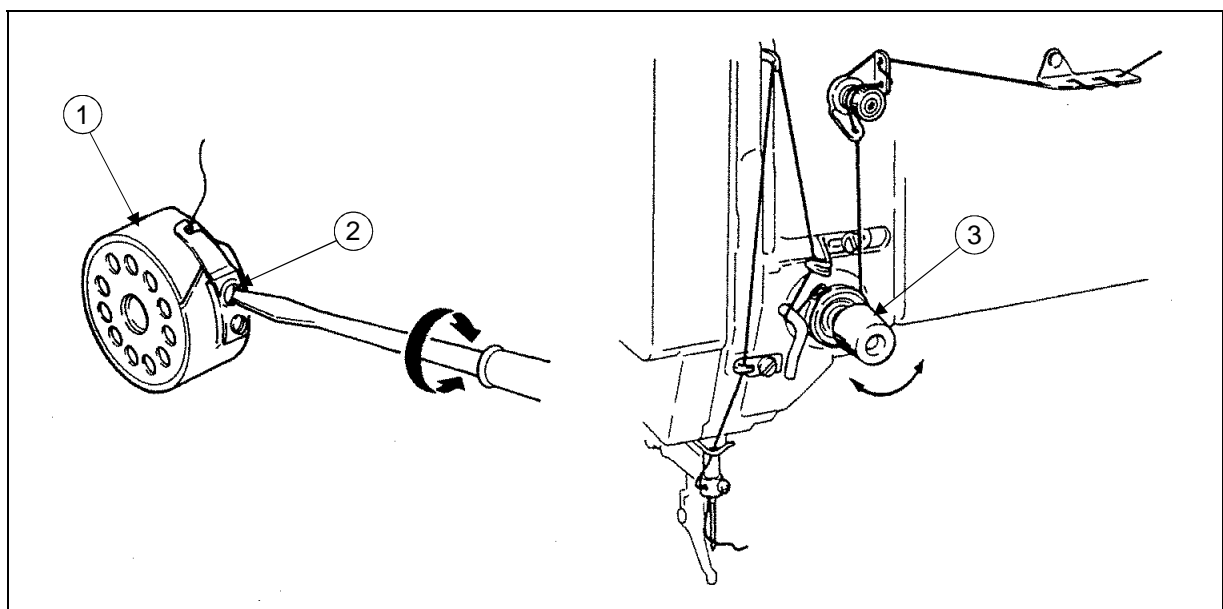

7. STANDARD ADJUSTMENT

! CAUTION

- ★ Please make sure to turn the power switch OFF before adjust the sewing machine.
- ★ If the adjustment is required under the power switch is ON, keep the start foot switch away from the foot.
- ★ Be careful not be wounded by the needle or the inner hook point.
- ★ Please make sure to put the safety guards (Eye guard, Belt guard and finger guard etc.) back on the original location after the sewing machine adjustment.

7-1 Adjustment of the needle bar position

- 1) Turn the power switch OFF.
- 2) Turn the sewing machine pulley by hand then, stop the needle bar (No.1) at the lowest position.
- 3) Remove the rubber plug (No.2) from the face plate then, loosen the needle bar holder set screw (No.3).
- 4) Move the needle bar (No.1) to the position where the needle bar timing mark A is matched to the needle bar bushing bottom line (No.4) then, tighten the needle bar holder set screw (No.3).

NOTE If the needle class is DPX5, match the needle bar timing mark B to the needle bar bushing bottom line (No.4).

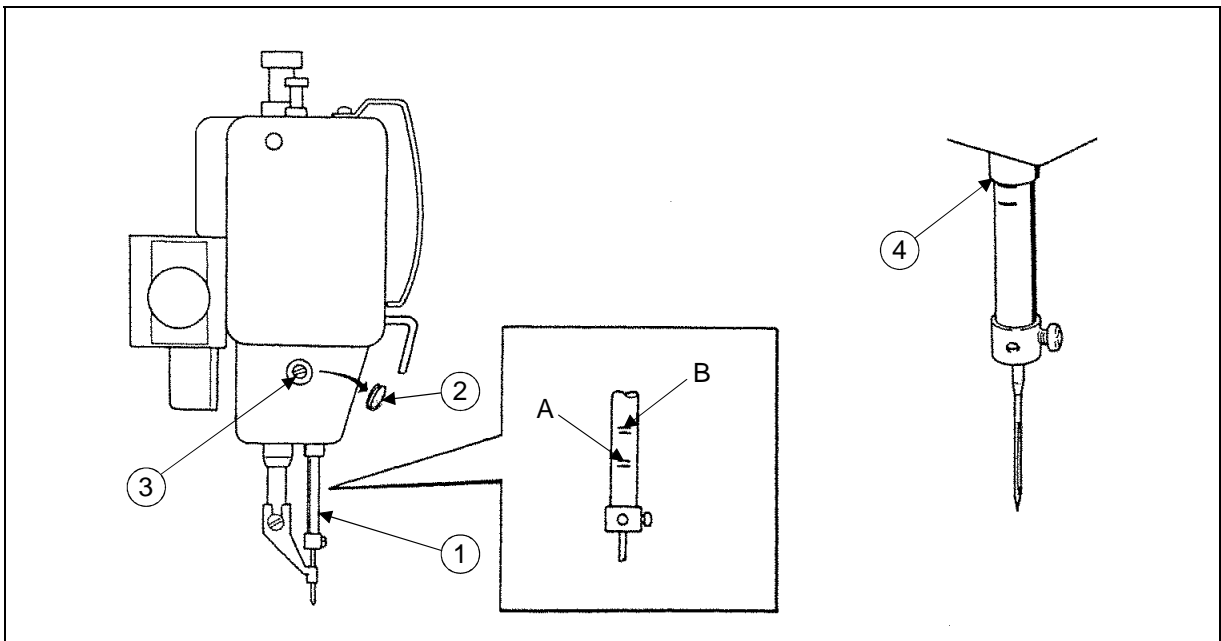

! CAUTION

- ★ For safety purposes, tilting or raising of the sewing machine must always be carried out by two or more workers. Apply a stopper on the leg casters to prevent the table from moving, and then securely support the bed base and the sewing machine head.
- ★ Hold the work holder frame to prevent it from dropping down when tiling the sewing machine.

7-2 Adjustment of the position between the needle and the rotating hook.

- 1) Turn the power switch OFF.
- 2) Open the cylinder cover (No.1).
- 3) Remove the bobbin case (No.2).
- 4) Loosen the set screws and remove the sliding plate (No.3).
- 5) Loosen the hook set screws (No.4).
- 6) Turn the sewing machine pulley by hand then, move up the needle bar (No.5) from the lowest position and stop it at the position (No.6) where the needle bar timing mark C is matched to the needle bar bushing bottom line.

NOTE If the needle class is DPX5, match the needle bar timing mark D to the needle bar bushing bottom line.

- 7) Turn the hook by hand and stop it at the position where the hook point (No.7) meets with the center line of the needle (No.8).
- 8) Move the look by hand and adjust the clearance between the hook point and the needle to be about 0.005 mm.
- 9) Hold the hook and tighten the hook set screws (No.10) securely.
- 10) After the adjustment, put the sliding plate (No.3) and bobbin case (No.2) back to the original locations and close the cylinder cover (No.1).

NOTE When put the sliding plate (No.3) back on the sewing machine, in order for the needle (No.9) to come into the right center of the needle hole of the needle plate (No.10), make sure that the needle plate hole center matches with the needle point then, tighten the set screws securely.

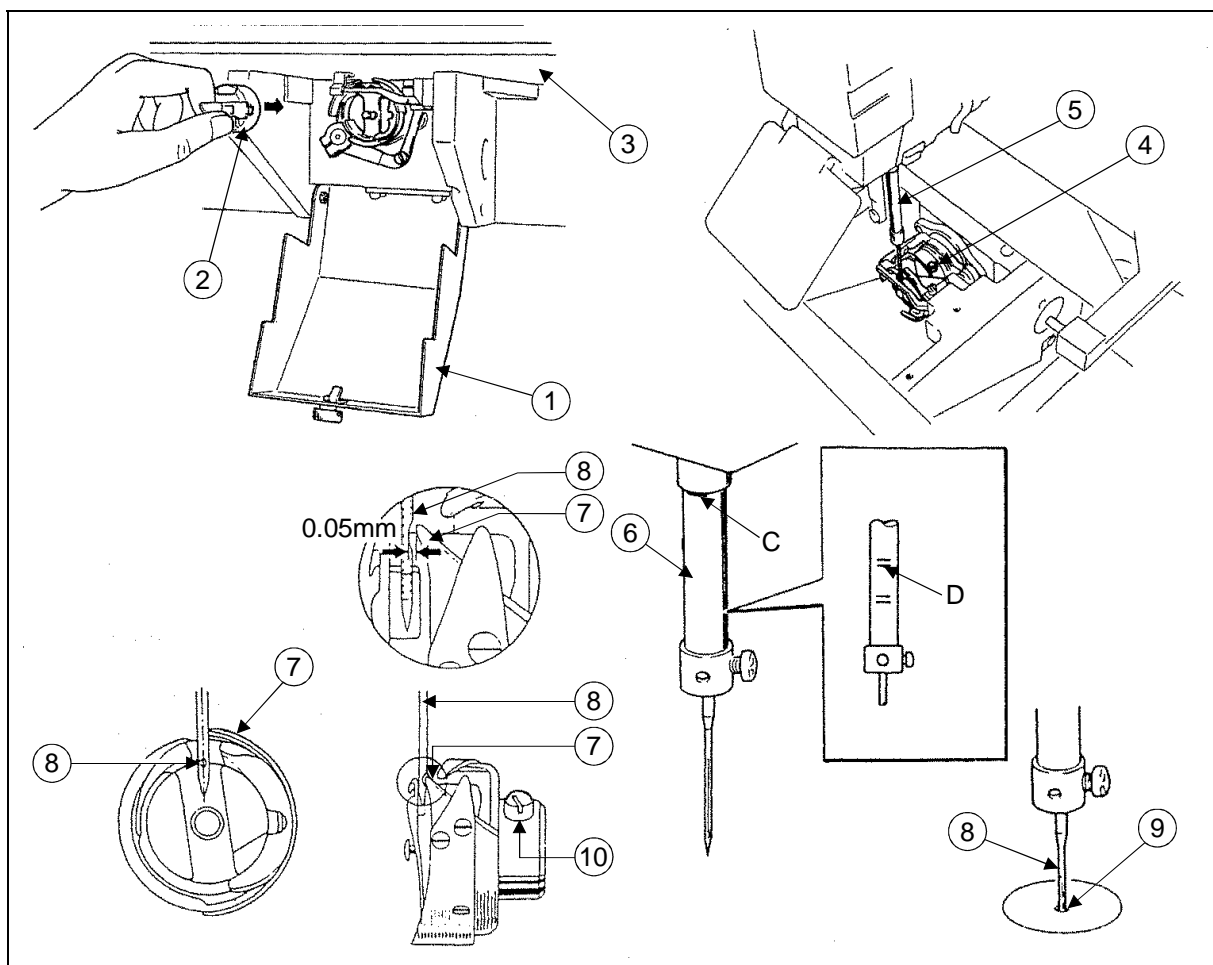

7-3 Adjustment of the hook positioner's position

- 1) Remove the sliding plate.
- 2) Loosen the hook positioner set screw (No.4) and adjust the hook positioner (No.1) position to align the right side of the projection (No.3) with the right side of the needle (No.2) as shown on the figure.
- 3) After the adjustment, securely tighten the hook positioner set screw (No.4) and put the sliding plate back on the sewing machine.

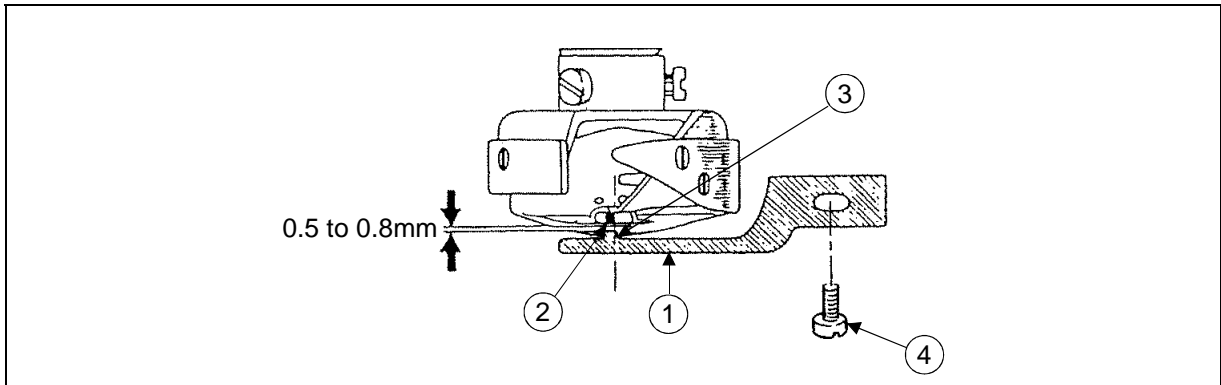

7-4 Adjustment of the lubrication for the rotating hook

- 1) Tilt the sewing machine head (No.1) to the left so that the bottom components can be seen.

! CAUTION

★ Please make sure to remove the small belt cover from the table top before tilting sewing machine head.

- 2) Loosen the set screws (No.2) and remove the cover (No.3).
- 3) Tighten the oil flow adjusting screw (No.4) lightly by fingers or a screw driver until it is stopped the turn.

NOTE Do not tight the oil flow adjusting screw (No.4) too much.

- 4) Adjust the oil flow in the range of one reverse turn from the deadlock position of the oil flow adjusting screw (No.4). The oil flow is decreased if loose the oil flow adjusting screw (No.4).
- 5) It can be checked the oil flow with the situation that the oil splashes on the paper covered over the running rotating hook.

For this checking, set the sewing machine ready to operate and remove the sliding plate so that the rotating hook is exposed, then cover the rotating hook with a paper and run the sewing machine.

- 6) After the adjustment, put the sliding plate, the cover (No.3) and the cylinder cover back to the original location.

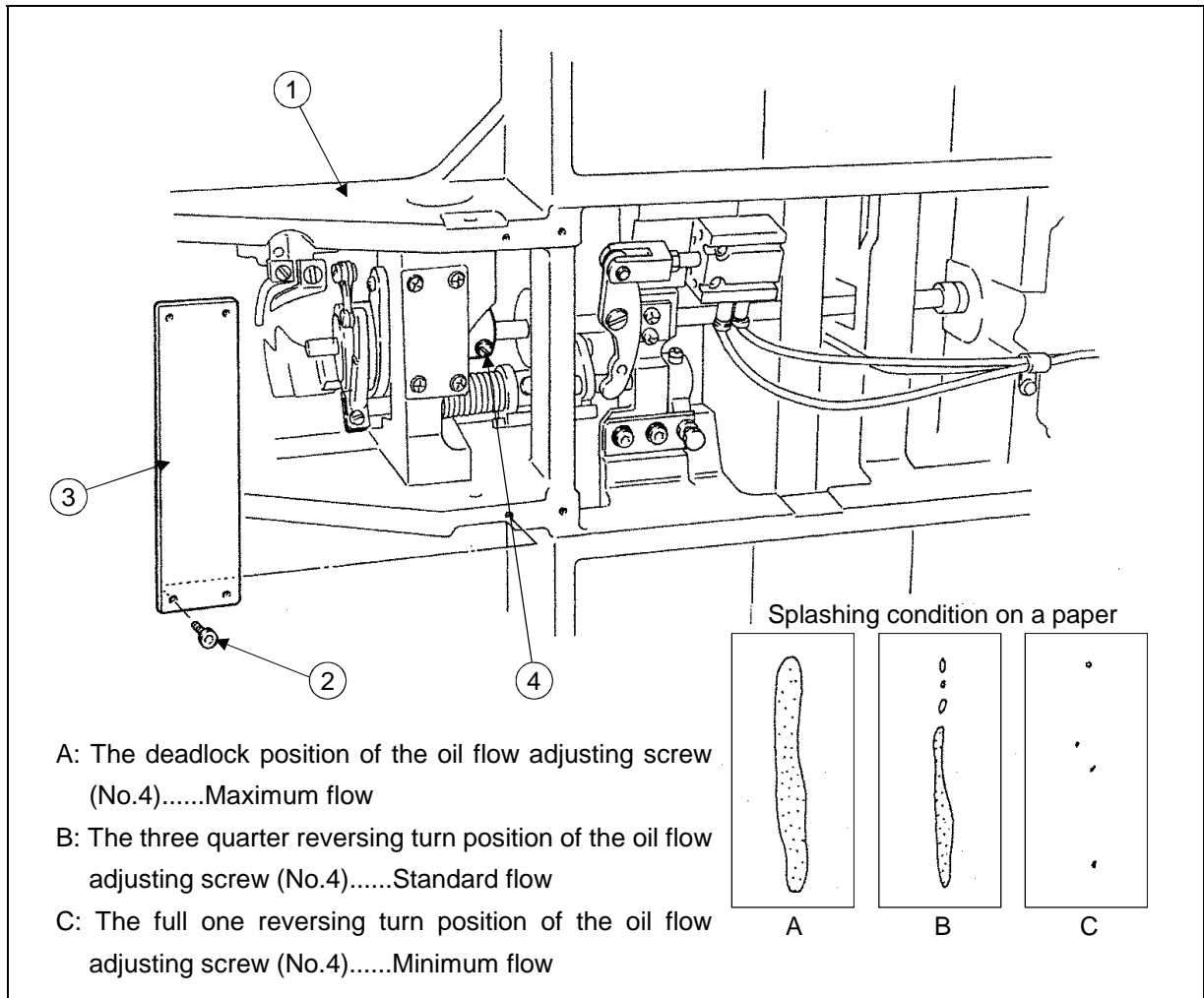

7-5 Adjustment of the presser foot

NOTE The presser foot is a very important part to form the fine stitches. It moves simultaneously with the needle and stabilize the needle penetrating area of the sewing material with pressing down it, when the needle sticks into or pulls out the sewing material and prevent the skip stitch or the cover penetration happening Please adjust the presser foot properly to the sewing materials with the following instructions.

7-5-1 Adjustment of the presser foot position

NOTE Please always adjust the presser foot position when the thickness of the sewing material is changed.

- 1) Turn the power switch OFF.
- 2) Remove the face plate (No.1) and the cover (No.2).
- 3) Turn the sewing machine pulley by hand and stop the needle bar (No.3) at the lowest position. At this time, make sure the set screw (No.5) of the eccentric cam (No.4) is positioned right beside the center line of the upper shaft. This is the standard position of the eccentric cam (No.4). If the eccentric cam (No.4) is off from this position, set it back to the standard position with the instructions in the paragraph [7-5-3. Adjustment of the presser foot timing] in the following page.

- 4) Turn the sewing machine pulley by hand and stop the needle at the highest position (this is also the thread take up lever's highest position). At this time, loosen the set screw (No.9) of the upper feed lock crank shaft (No.8) and adjust the center line of the bell crank (No.6) to be parallel with the presser foot bar (No.7).
- 5) Insert the sewing material (No.10) under the work holder (No.11) and turn the sewing machine pulley by hand then, stop the presser foot (No.12) at the lowest position.
- 6) Loosen the presser foot bar set screw (No.14) and move the presser foot bar (No.7) then, adjust the presser foot (No.12) position to become the clearance between the bottom surface of the presser foot (No.12) and the surface of the sewing material 0 to 0.5mm. At the same time, rotate the presser foot bar (No.7) for the needle (No.15) to come down to the center of the needle hole of the presser foot (No.12).
- 7) After the adjustment, put the face plate (No.1) and the cover (No.2) back on the original location.

NOTE The lower position of the presser foot, the more effective for the skip stitches. However, if the presser foot become to press the sewing material, the movement of the presser foot mechanism generates a slight noise. And also, the presser foot stays longer to hold the sewing material, so the upper thread tension becomes loose or the sewing pattern forming gets out of shape because the presser foot catches the surface of the sewing material. For avoiding these troubles, please lower the presser foot as small as possible.

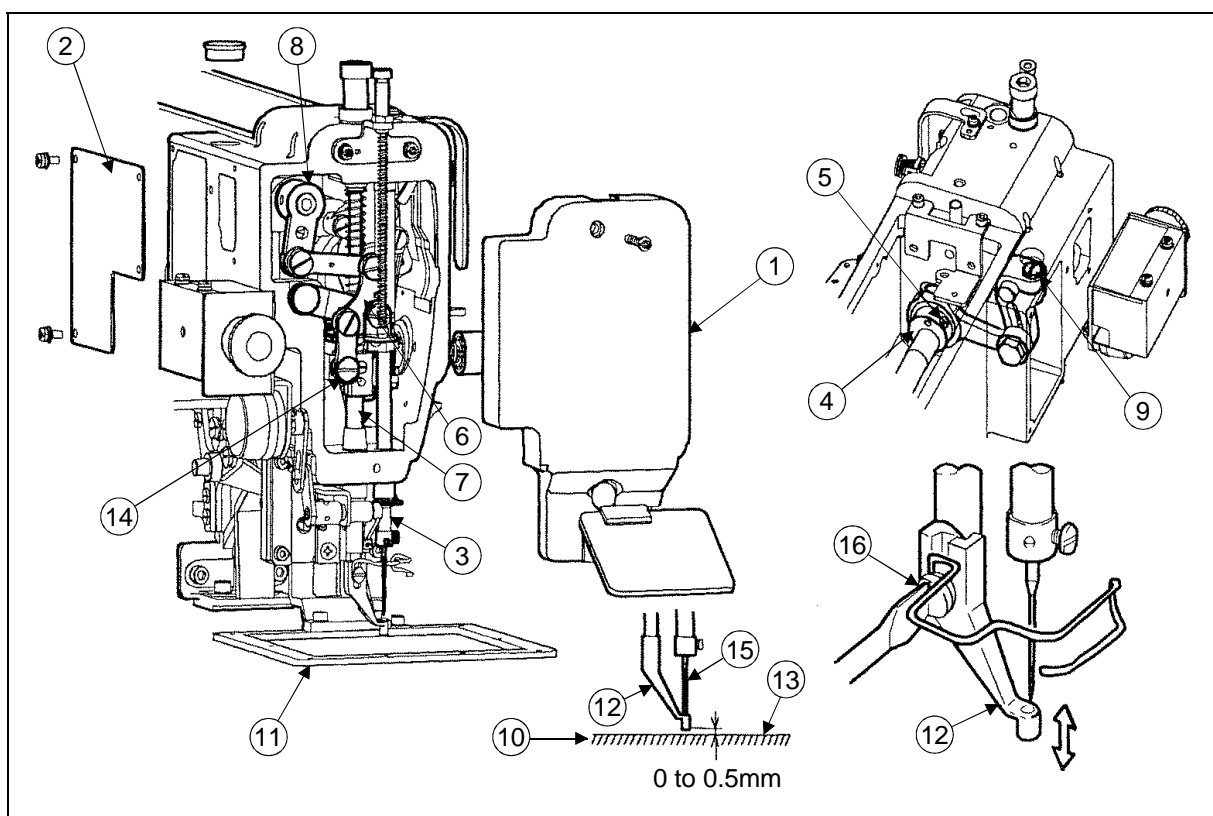

NOTE If the thickness of the sewing material changes very often, it is recommended to take this easy way for the adjustment of the presser foot position with the method that change only the fixed position of the presser foot after fixed the presser foot bar at higher position.

For this adjustment, loosen the set screw (No.16) then, move the presser foot (No.12) up and down.

7-5-2 Adjustment of the presser foot lift during the sewing

NOTE The presser foot lift during the sewing can be adjusted 0 and 2 to 10mm.

- 1) The presser foot lift during the sewing becomes 4 to 10mm at the condition which the connection of the link (No.2) and the lever (No.3) with the shoulder screw (No.1) is as shown on the figure and becomes 2 to 4mm if the connection is made with A hole, and it becomes 0mm if the connection is made with B hole..
- 2) The stepping lift is adjusted 4mm when the sewing machine is shipped from the factory.
- 3) For the adjustment at the each range of the presser foot lift, remove the cover (No.4) then, loosen and move the adjust bolt (No.5).
- 4) If the link (No.2) connection is changed to A or B hole, the presser foot position is also changed. So reset the presser foot position with adjusting the position of the presser foot bar or the presser foot itself with loosening their set screws (No.6) or (No.7).
- 5) Regarding the running noise and the vibration, the higher lift effects worse. So adjust the presser foot lift during the sewing as small as possible.
- 6) After the adjustment, put the cover (No.4) and the face plate (No.8) back on the original location.

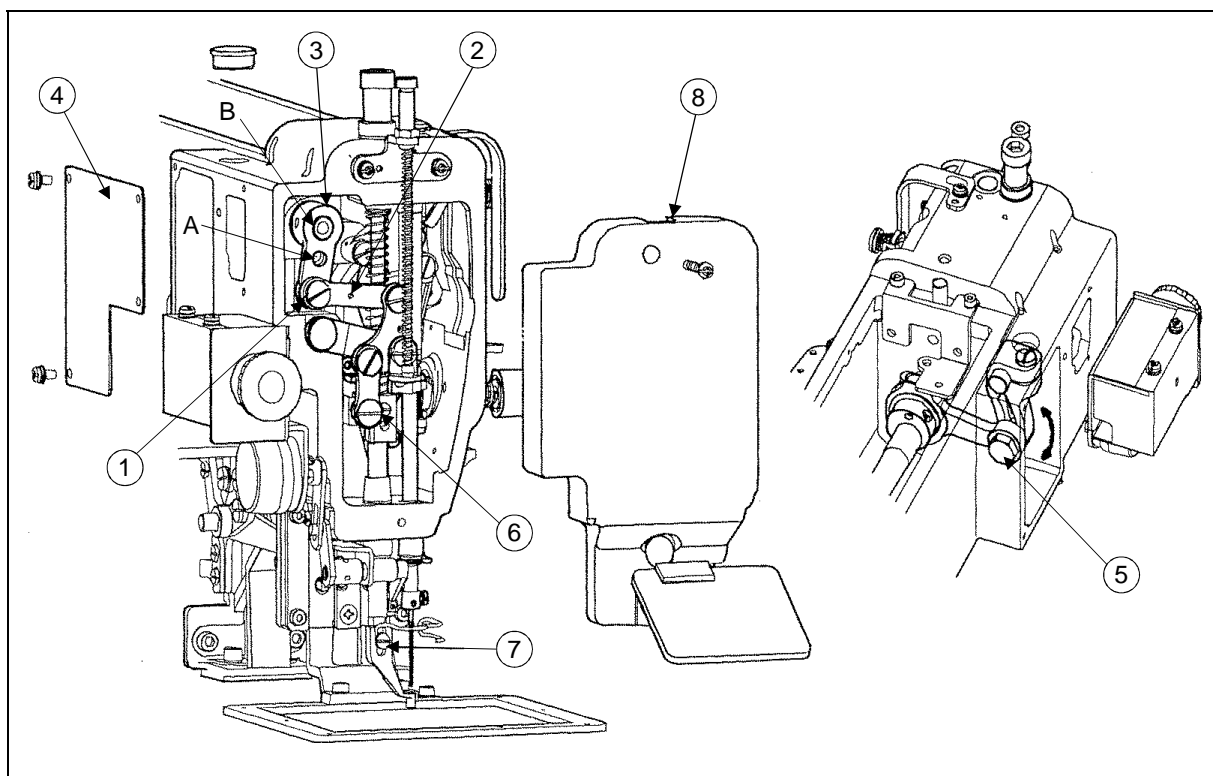

7-5-3 Adjustment of the presser foot timing

NOTE The presser foot up and down movement during the sewing synchronizes with the needle up and down movement. With changing this synchronized timing to the sewing materials, the skip stitches can be prevented or the seam tightness can be improved.

For example, the delay of the presser foot timing against the needle movement prevents the skip stitches especially to the thin materials, and the advance of the presser foot timing can improve the seam tightness especially to the thick materials.

- 1) Remove the cover (No.1).
- 2) Loosen the set screw "C" of the eccentric cam (No.2).
- 3) Turn the sewing machine pulley by hand and stop the needle bar (No.3) at the lowest position. At this stage, the set screw "A" of the eccentric cam (No.2) is positioned right beside the center line of the upper shaft. This is the standard position for the eccentric cam (No.2).
- 4) Loosen the set screw "A" of the eccentric cam (No.2).
- 5) Hold the eccentric cam (No.2) and turn the sewing machine pulley slowly by hand. If turn the sewing machine pulley to the arrow direction "D", the presser foot timing against the needle movement is delayed, and if turn the pulley to the opposite direction, the timing of the presser foot is advanced.
- 6) After the adjustment, tighten the set screw "A" and "C" in turn with slightly pushing the eccentric cam (No.2) to the arrow direction "E".
- 7) Put the cover (No.1) back on the original location.

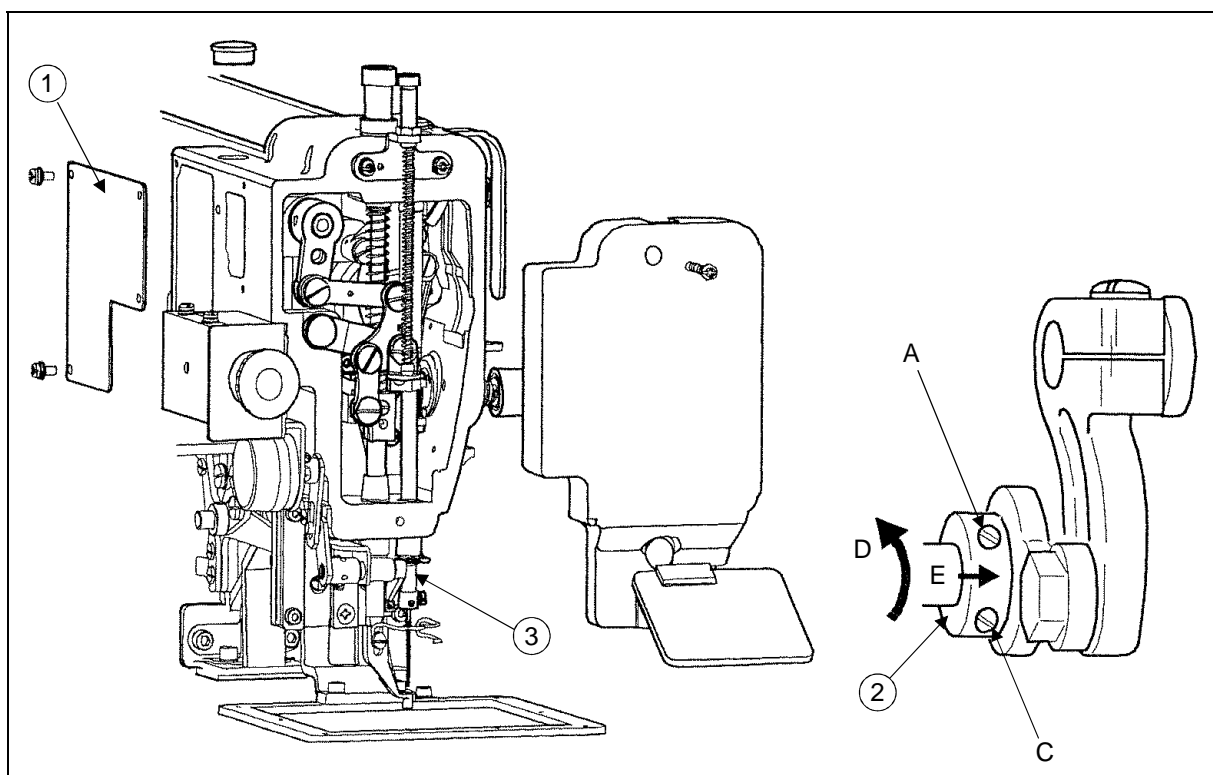

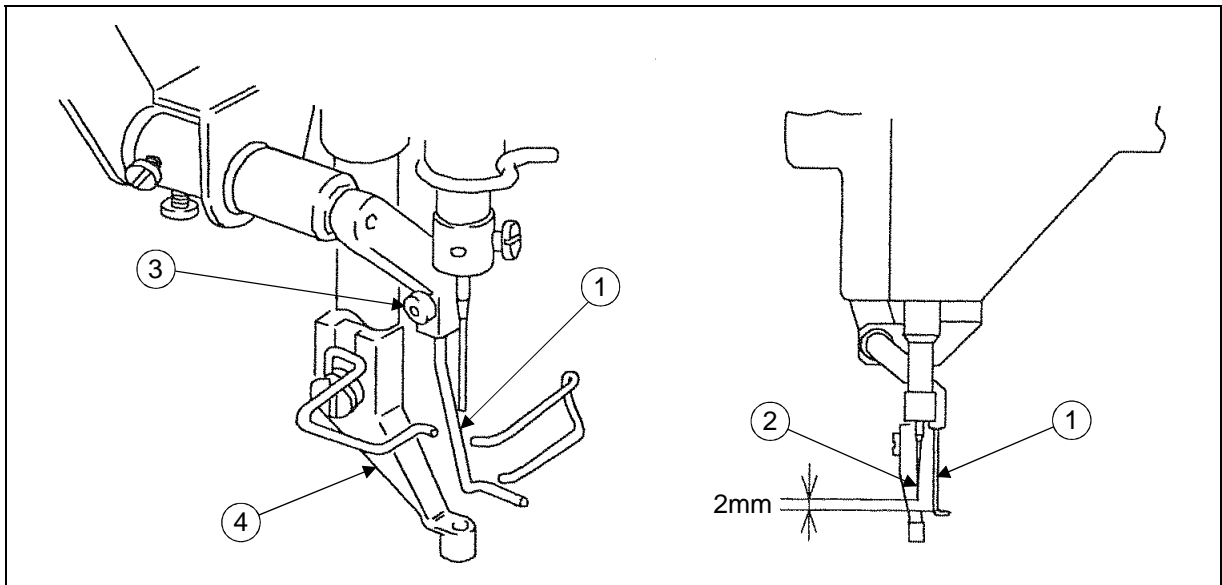

7-6 Adjustment of the wiper

- 1) Loosen the wiper set screw (No.3) and adjust the wiper (No.1) to be positioned where the wiper (No.1) passes under the needle point (No.2) with about 2mm clearances right after the sewing machine is stopped running at the needle upper position (the thread take up lever's highest position).

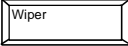

NOTE When the presser foot position or the presser foot lift is changed, the wiper (No.1) may collide with the presser foot (No.4). In that case, please do not use the wiper (No.1).

- 2) If do not use the wiper (No.1), cancel the wiper function with the operation panel as follows.
 - a) Press the  MENU key at the normal mode condition, then MENU MODE is appeared.
 - b) Press the  Program key. Then below screen will be appeared.
 - c) Press the  Wiper key.
 - d) And then press the [WIP] key and select the [OFF] key.

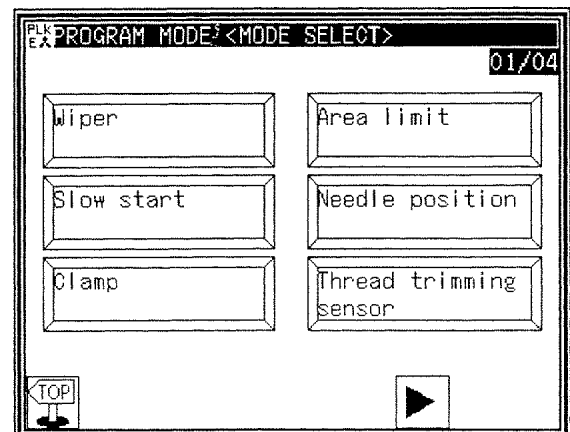
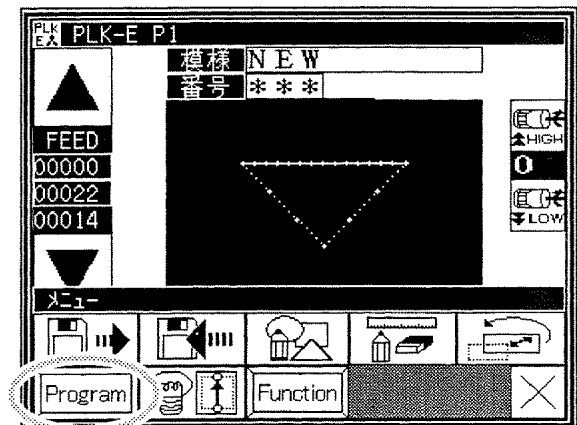

7-7 Adjustment of the bobbin wiper

1) Adjustment of the wiper volume

Loosen the set screw (No.2) of the adjusting lever (No.1) and adjust the position of the adjusting lever (No.1). If move the adjusting lever (No.1) to the arrow direction "a" the winding volume is reduced, and if move the adjusting lever (No.1) to the arrow direction "b", the winding volume is increased. The winding volume is adjusted 80% of the full volume when the sewing machine is shipped from the factory.

2) Adjustment of the proper position of the bobbin winder

Firstly, loosen the set screw (No.3) and (No.4) of the bobbin winder and put the empty bobbin (No.5) on the rotating shaft (No.6) then, push the adjusting lever (No.1) to the arrow direction "a". Secondly, move the whole bobbin winder to the arrow direction "c" and stop it at the position where the empty bobbin is rotated then, tighten the set screw (No.3) and (No.4) of the bobbin winder. This is the proper position of the bobbin winder.

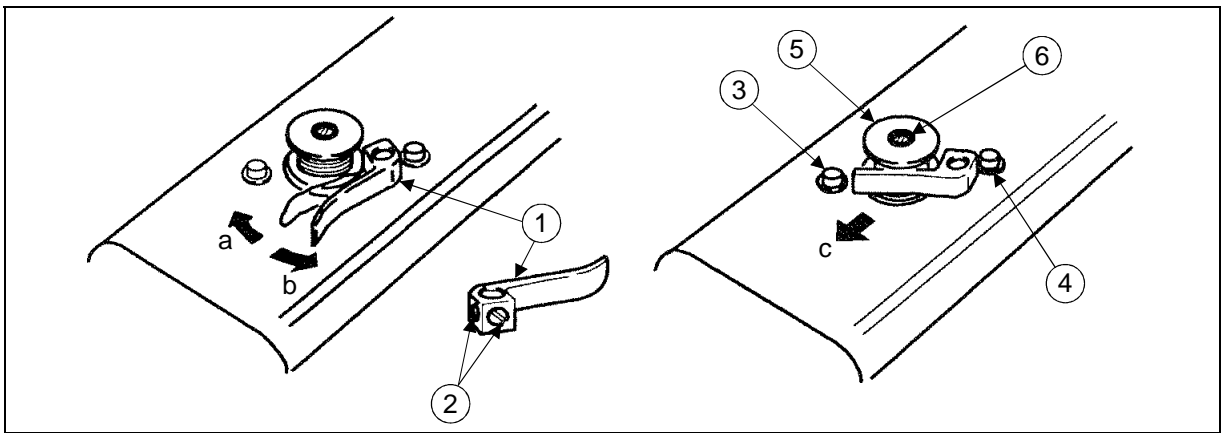

7-8 Adjustment of the work holder

7-8-1 Adjustment of the work holder pressure

! CAUTION

★If the secondary side air pressure is set too high, trouble such as operation faults may occur. Always set the pressure to within 0.4Mpa.

The work holder pressure is provided from an air source.

Lift and turn the air regulator's adjustment knob (No.1) located under the table to adjust the air pressure.

If turn the adjusting knob (No.1) to the clockwise, the air pressure is increased and the work holder pressure is also increased simultaneously.

If turn the adjusting knob (No.1) to counter clockwise, the air pressure is decreased and the work holder pressure is also decreased simultaneously.

0.4Mpa (4kgf/cm²) is the standard air pressure as a normal sewing operation.

7-8-2 Changing the work holder

- 1) Remove the work holder (No.3) by pressing it down from the engaged area with the pin (No.4) of the work holder yolk.
- 2) Prepare another work holder and securely engaged its U shaped motise (No.5) with the pin (No.4) of the work holder yolk.

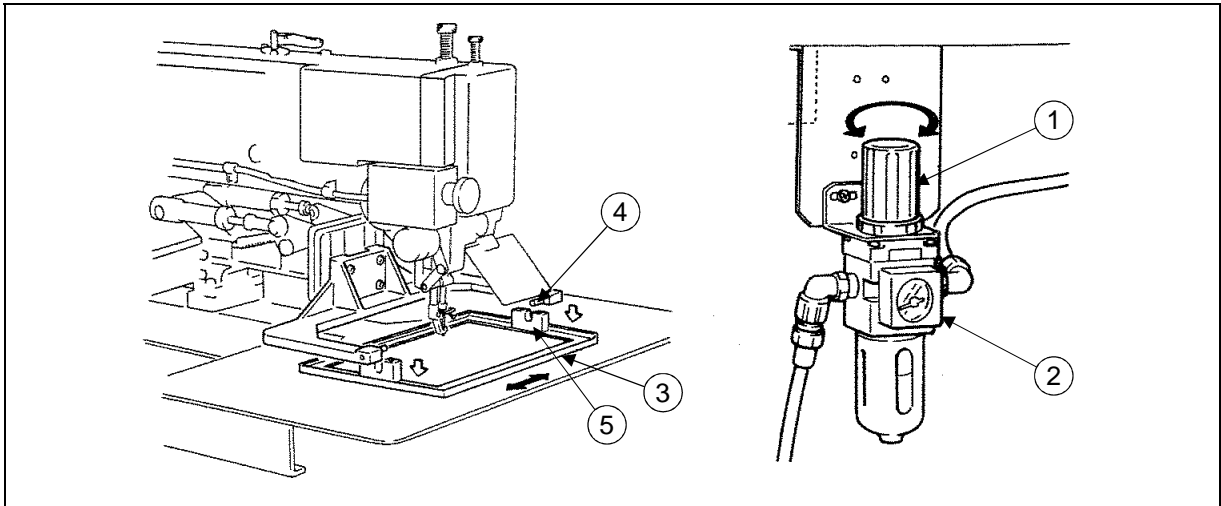

7-9 Adjustment of the thread trimmer

7-9-1 Structure of the thread trimmer mechanism

The thread trimmer mechanism of sewing machine is shown on the figure.

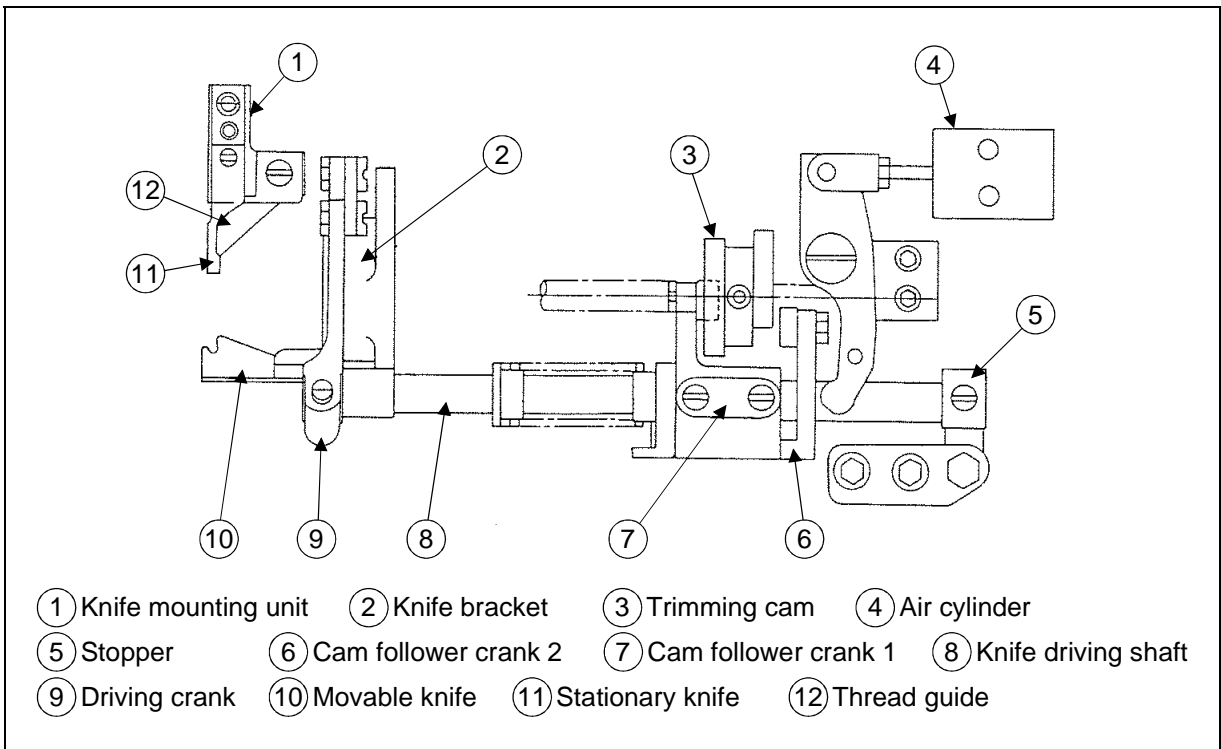

! CAUTION

★A lower shaft cam method is incorporated for the thread trimmer mechanism. When adjusting the sewing machine, if the thread trimmer air cylinder is in the operable state (state in which the cam follower crank 2 arm is engaged with the thread trimmer cam) and the upper shaft is rotated, the movable knife will collide with the needle and cause damage.

For avoiding this incident, always activate the air cylinder only in the regular trimming cycle which the needle moves from its lower to upper position.

7-9-2 Assembling and readjustment of the thread trimmer mechanism

If take the trimmer mechanism apart and assemble it again, please refer to the following instructions for the readjustment.

7-9-2.1 Attaching the knife bracket and the knife mounting unit

1) Knife bracket

Under the condition that the rotating hook and the hook positioner are removed, put the knife bracket (No.1) on the lower shaft left bushing (No.2) and fix it with the two set screws (No.3).

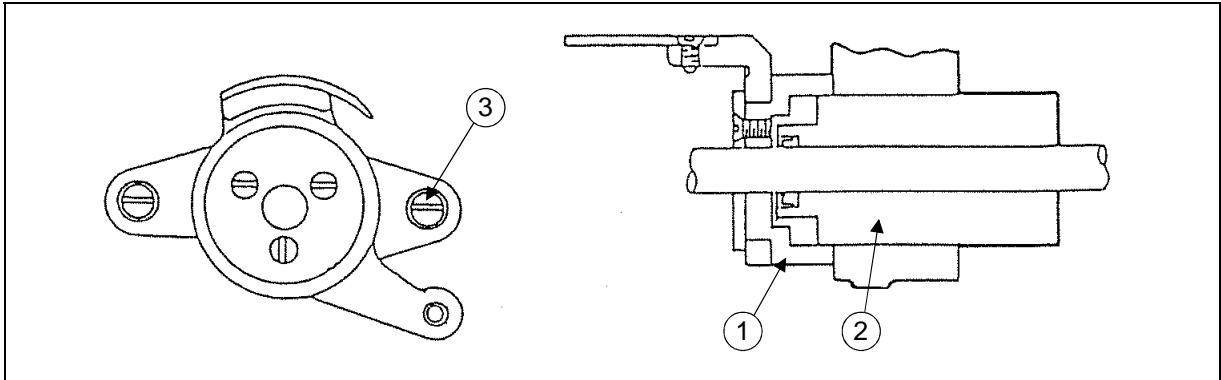

2) Knife mounting unit

Under the condition that the rotating hook and the hook positioner are removed, attach the knife mounting unit (No.1) with the set screw (No.2).

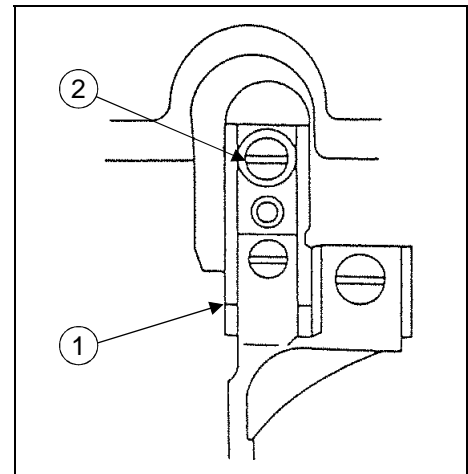

7-9-2.2 Mutual relation among the movable and stationary knife edge

- 1) Rotate the movable knife (No.1) by hand when it is engaged with the stationary knife (No.2), there is 0.3mm space between the movable and stationary knife edges. This is standard condition.
- 2) If this space is too wide, it causes a thread tail from the needle to be pulled out after the automatic thread trimming. And if it is too narrow, it causes the failure of the trimming.
For avoiding these incidents, please adjust this space precisely.
- 3) For this adjustment, suitably move the knife bracket or the knife mounting unit mentioned at above 7-9-2.1.

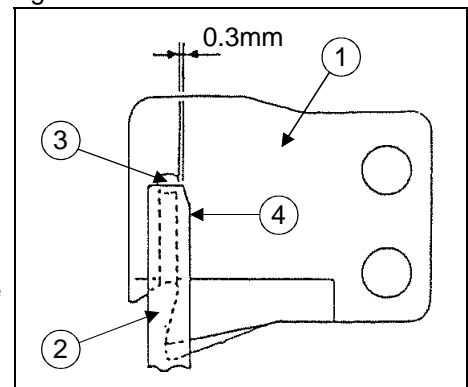

7-9-2.3 Connection of the knife bracket and the driving crank

- 1) Connect the knife bracket (No.1) and the driving crank (No.2) with the link (No.3).
- 2) Loosen the driving crank set screw (No.4) and adjust the attaching position of the driving crank (No.2) in the right and left direction so that the link (No.3) can contact with the same flat surface of the knife bracket (No.1) and the driving crank (No.2) without any distortion. After the adjustment, tighten the driving crank set screw (No.4) securely.

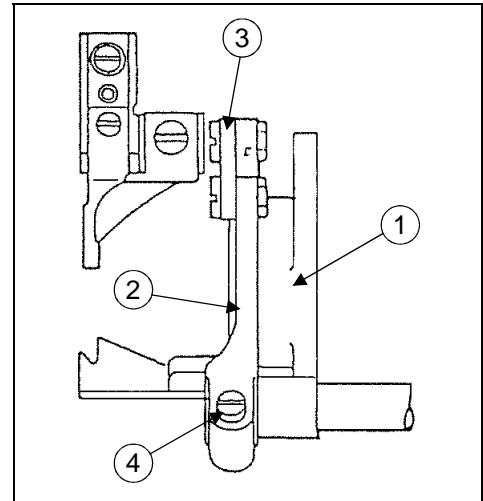

7-9-2.4 Adjustment of the component parts of the knife driving mechanism

- 1) Attach the component parts of the knife driving mechanism and adjust the locations as shown on the figure.
- 2) When assembling the parts always, firstly insert the knife driving shaft (No.6) into the driving crank (No.1).
- 3) Fix the cam follower crank 1 (No.3) on the knife driving shaft (No.6) at the right end position 77mm away from the front surface of the sewing machine bed as shown on the figure.
- 4) Fix the stopper (No.5) on the knife driving shaft (No.6) by tightening the set screw (No.7) at the flat cut of the shaft.

At the time, make sure there is no play on the knife driving shaft (No.6) in the axial direction and it can be rotated smoothly.

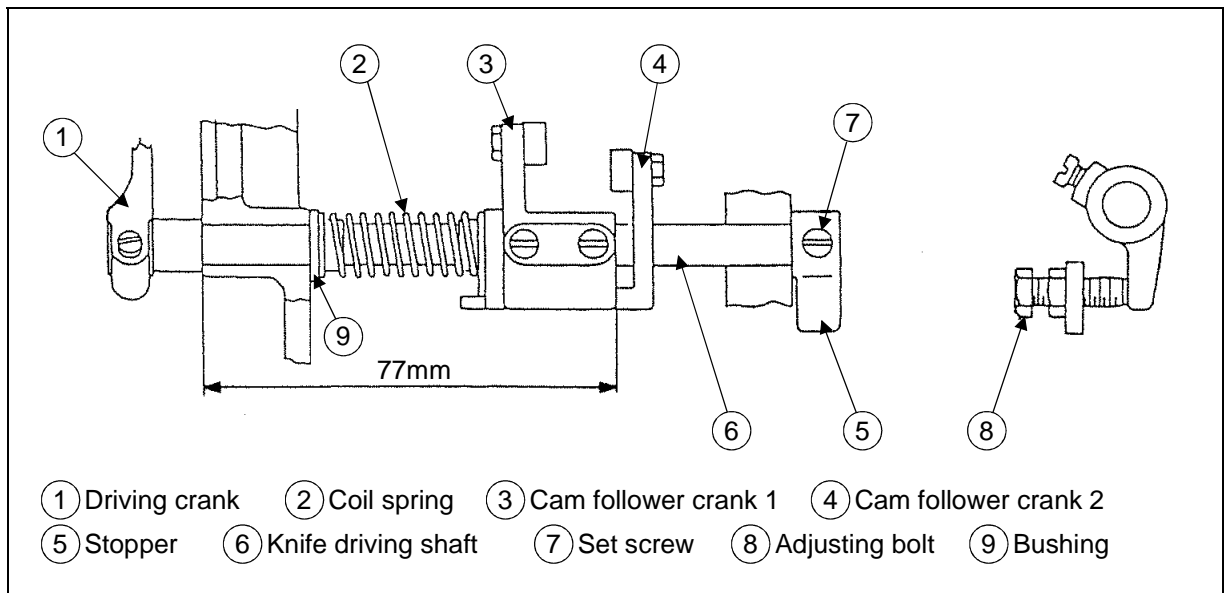

7-9-2.5 Adjustment of the mounting position of the air cylinder

- 1) Attach the thread trimmer air cylinder (No.1) by fixing with the bolt (No.2) When the thread trimmer air cylinder (No.1) is released, there will be a clearance of approx. 1mm at section **A**. To adjust this clearance, loosen the set screw (No.4) for the mounting plate (No.3), and move the entire mounting plate (No.3).

After adjusting, securely tighten the set screw (No.4) for the mounting plate (No.3).

- 2) When the thread trimmer air cylinder (No.1) is activated, there will be a clearance of 0.5mm between the cam follower crank 1 (No.5) and cam follower crank 2 (No.6). This is the standard state. This clearance can be adjusted by loosening nut (No.7) for the air cylinder (No.1), and rotating the shaft section (No.8) of the air cylinder (No.1).

After adjusting, securely tighten the nut (No.7) for the air cylinder (No.1).

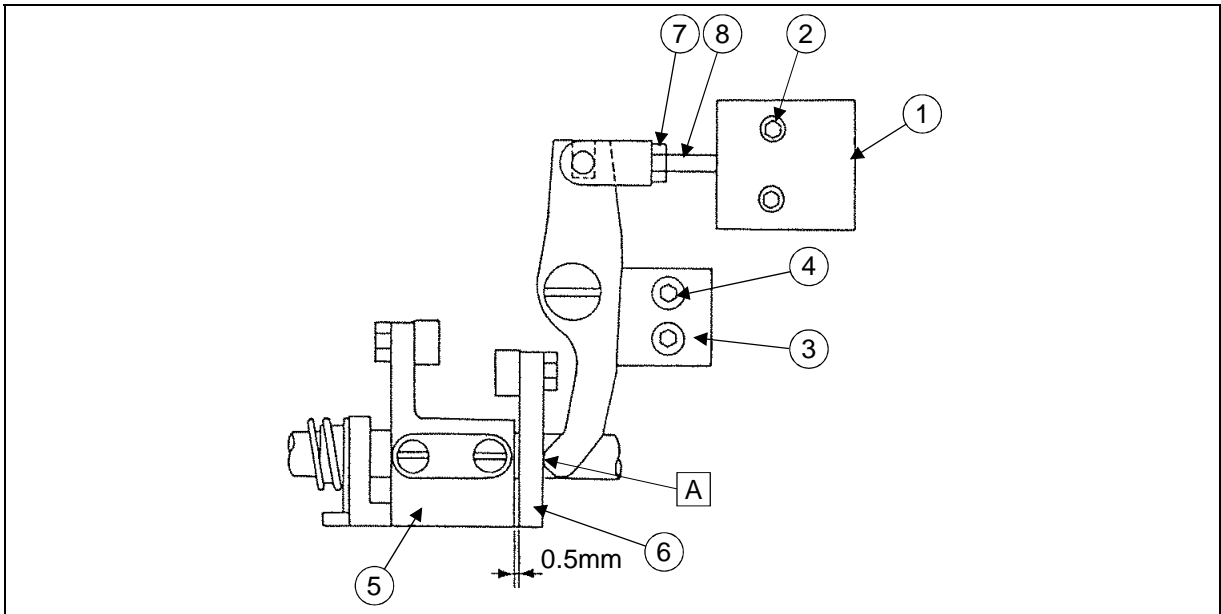

7-9-2.6 Adjustment of the mounting position of the thread trimmer cam

NOTE Before the trimmer mechanism is activated, the cam follower crank 2 (No.1) is located under the condition that a point of tangency of the cam follower (No.4) is over the tangential line of the cam shaft (No.2) and the lower shaft (No.3) at 3mm distance. This is the standard condition. Make the following adjustments based upon this standard condition. If this standard condition is changed by such removing the stopper (No.5), set the cam follower crank 2 (No.1) back to the standard condition with the adjusting bolt (No.6).

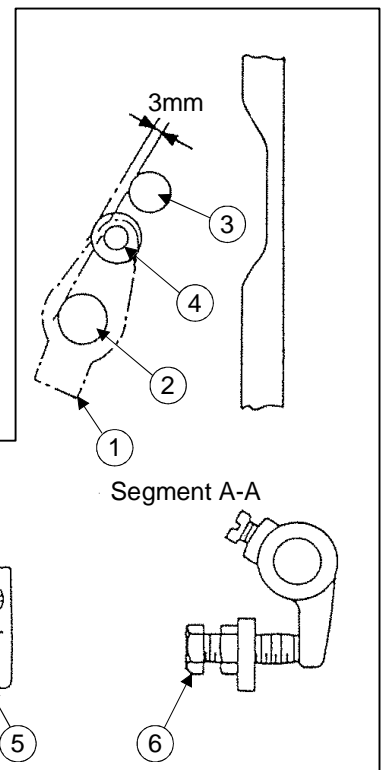

1) Loosen the two set screws (No.9) of the thread trimming cam (No.8).

Turn the sewing machine pulley (No.10) by hand match the second timing mark (No.11) of the machine pulley (No.10) with the arm timing mark (No.12).

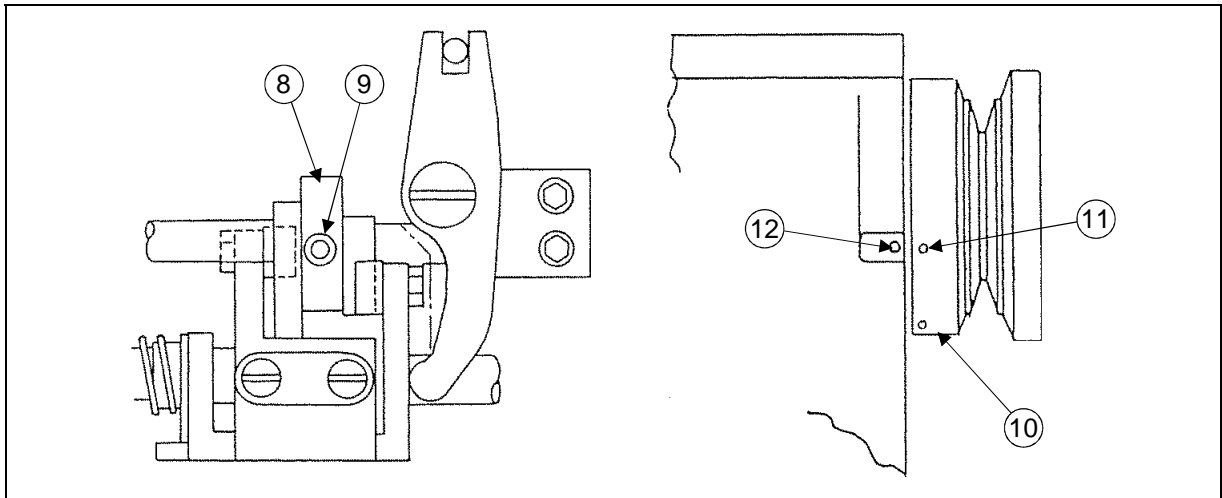

2) Make the air cylinder activated condition, then turn the thread trimmer cam (No.8) in the arrow A direction by hand.

Fix the thread trimmer cam (No.8) with the two set screws (No.9) at the point where the thread trimmer cam (No.8) contact with the cam follower (No.13).

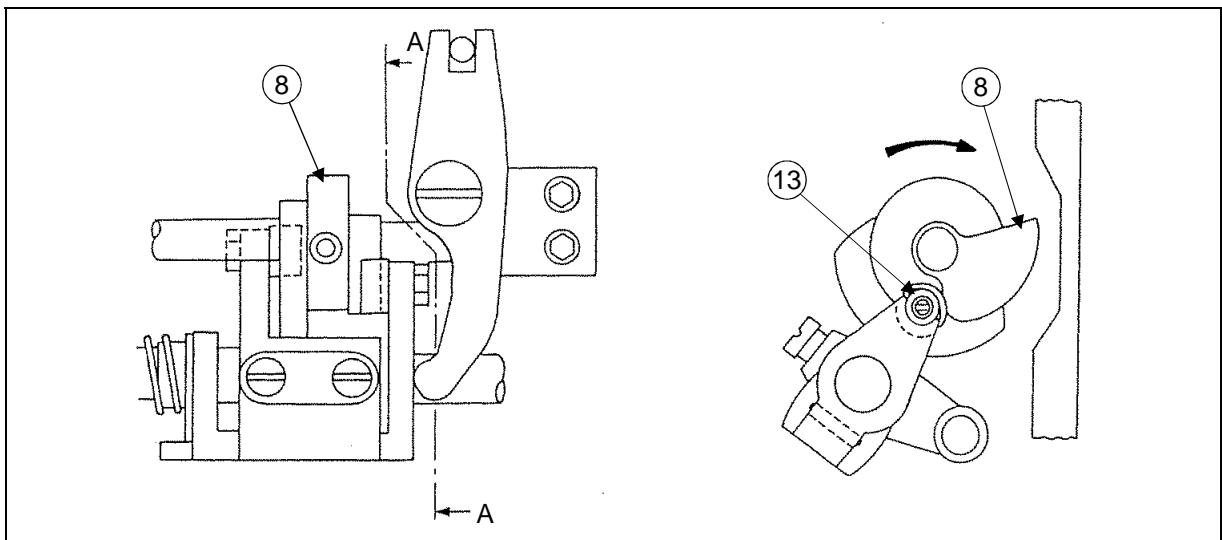

3) Make sure that the clearance between the thread trimmer cam (No.8) right end and the cam follower (No.13) left end is 0.5mm to 1.0mm when the cam follower crank 2 (No.14) is returned to the B arrow direction after the air cylinder is set back to the original condition. This is the standard condition.

If the clearance is out of this amount, loose the set screws (No.9) of the thread trimming cam (No.8) and readjust the location of the thread trimming cam (No.8) for the clearance to be within the amount, then tighten the set screws (No.9) again.

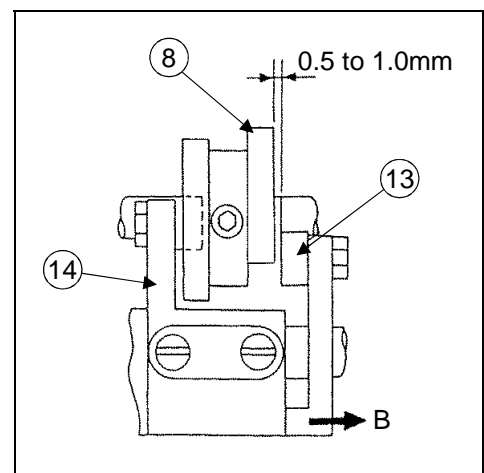

7-9-2.7 Adjustment of the knife engagement

1) The standard position for the movable and stationary knife

The standard mutual position for the movable (No.1) and stationary (No.2) knife is as shown on the figure.

2) Adjustment of the amount for the knife engagement.

Activate the thread trimmer air cylinder, and rotate the upper shaft. The movable knife (No.1) will rotate with the thread trimmer cam. When the edge of movable knife (No.1) is reached at most left position, the amount of the engagement with the stationary knife (No.2) becomes 1.5mm to 2.0mm.

This is the standard condition. For this adjustment, loosen the set screw (No.4) of the driving crank (No.5), then move the driving crank (No.5) to have the proper engagement.

After the adjustment, tighten the set screw (No.4) of the driving crank (No.5) securely.

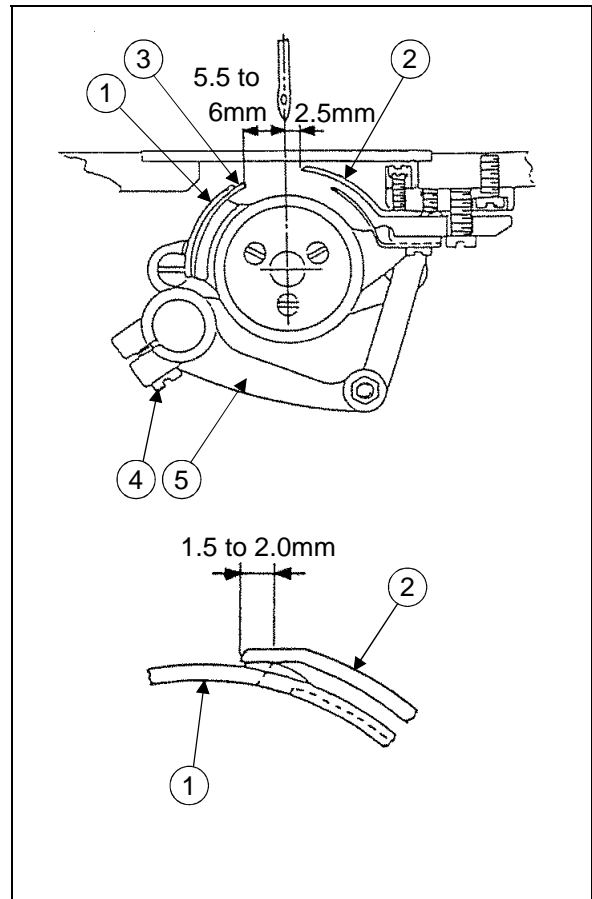

3) Adjustment of the engaging presser for the knives

- a) The engaging presser for the movable (No.1) and stationary knife (No.2) can be controlled with adjusting the height of the stationary knife (No.2). When the movable knife (No.1) is rotated, the contact of the both knives starts from the position where the distance between the edge of the stationary knife (No.2) and the cut out line of the movable knife (No.1) is 3mm. This is the standard condition.

- b) If the trimming condition is not sharp enough to a bigger thread, it can be improved with increasing the knife engaging presser a little bit.

- c) For the adjustment of this knife engaging presser, loosen the lock nut (No.4), then adjusting screw (No.5). If tighten the adjusting screw (No.5), the knife engaging presser becomes tight and if loosen the adjusting screw (No.5), it becomes loose. After the adjustment, tighten the lock nut (No.4) securely.

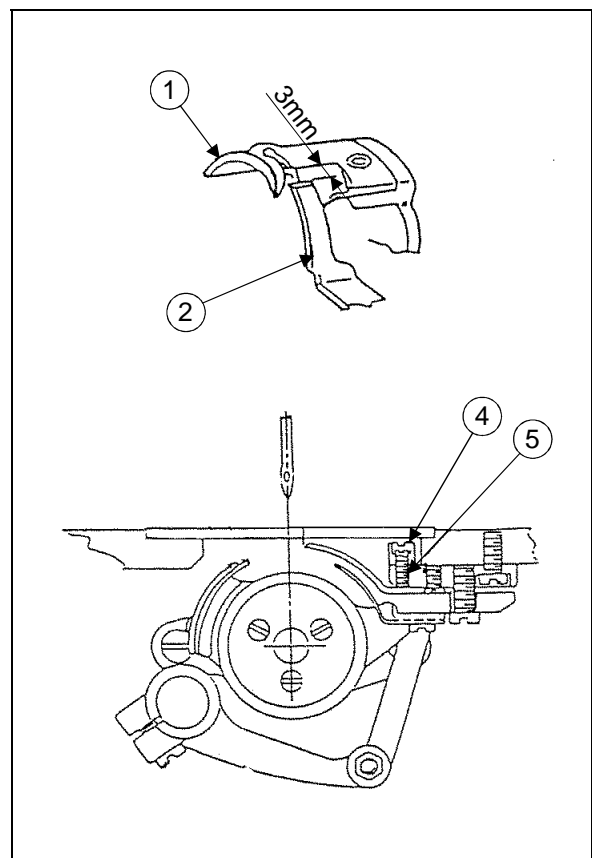

- 4) Adjustment of the attaching position of the protector
 Attach the protector (No.6) underneath the movable knife (No.1) and fix it with the same set screw (No.7) for the movable knife (No.1) at the position where the point of the protector (No.6) is off 0.5mm left from the needle center (No.4) and 4mm backward from the point of the movable knife (No.1).

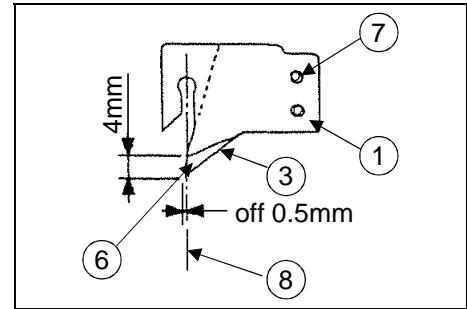

7-10 Adjustment of the upper thread tension release

- NOTE** a) The upper thread tension release works when the upper thread is trimmed automatically or the presser foot is lifted during the work holder feeding.
- b) If the upper thread tension release does not work properly when the upper thread is trimmed automatically, the thread tail from the needle becomes shorter then, it induces the skip stitch happening or pulling the thread tail out of the needle at the start of the sewing.
- c) During the sewing operation, the discs (No.1) of the thread tension regulator is closed while the presser foot is moving up and down.
- If the discs (No.1) of the thread tension regulator is not closed, the upper thread tension becomes loose and the proper stitch condition can not be obtained.
- d) When the upper thread tension release is activated, the discs (No.1) the upper thread tension regulator opens 0.8 to 1.0mm. This is the normal condition of the discs (No.1) opening. For this adjustment, take the following procedure.

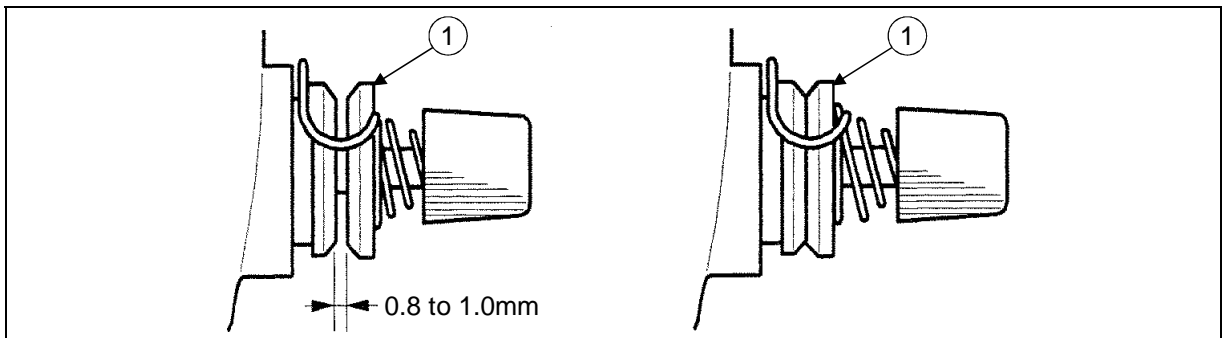

- 1) Remove the top covering.
- 2) Fully turn the crank (No.3) of the rotary solenoid (No.2) in the arrow direction. At this time, adjust the upper thread tension release so that the discs can be opened 0.8 to 1.0mm.
- 3) For this adjustment, loosen the nut A then, if tighten the nut B, the discs opening becomes wider and if loosen the nut B, it becomes narrower.
- 4) If the normal opening of the discs can not be obtained with the nut adjustment, loosen the wire fix screws (No.4) and adjust the tension of the wire (No.5).
- 5) The wire (No.5) may be got longer over a long period machine operation. At that time, adjust the upper thread tension release again.

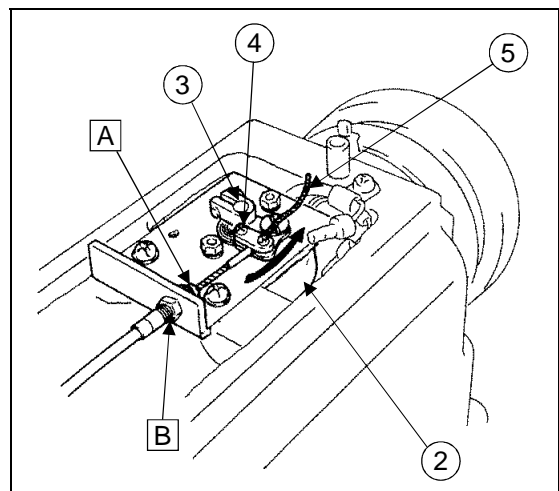

7-11 Adjustment of the thread rail after the trimming

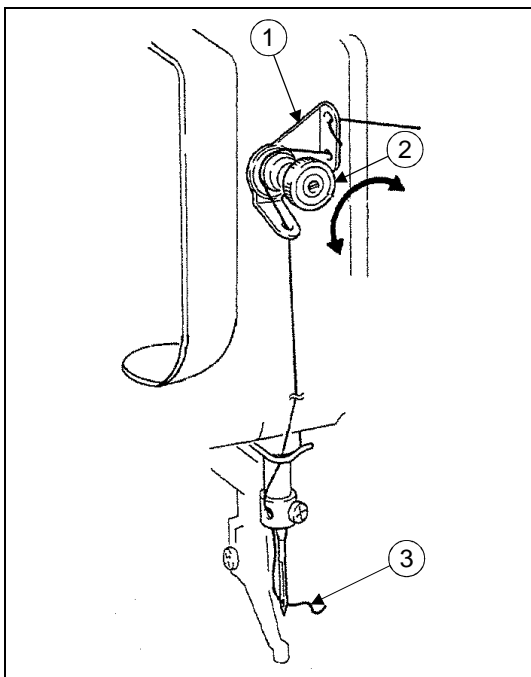

Adjust the thread tail (No.3) from the needle after the trimming with turning the nut (No.2) of the pretension (No.1).

If turn the nut (No.2) to the clockwise, the thread tail becomes shorter and if turn the nut (No.2) to the counter-clockwise, the thread tail becomes longer.

7-12 Cancellation of the trimming function

If the automatic trimming is not required during the sewing operation, cancel the trimming function with the operation panel.

For the detail of this instructions, please refer to the paragraph [16.Program mode or 17.Program mode list] on the technical manual [Operation Panel](#).

7-13 Adjustment of the thread take up spring swing stroke

Loosen the set screw (No.2) and turn the whole thread tension regulator (No.3) then, adjust the thread take up spring swing stroke to be become 9 to 10mm.

After the adjustment, tighten the set screw (No.2) securely.

7-14 Adjustment of the thread take up spring tension

Insert the screw driver (No.5) into the slit (No.4) of the thread tension regulator (No.3) and adjust the thread take up spring (No.1) tension. If turn the screw driver to the clockwise, the thread take up spring tension becomes tight, and if turn the screw driver to the counter clockwise, the thread take up spring tension becomes loose.

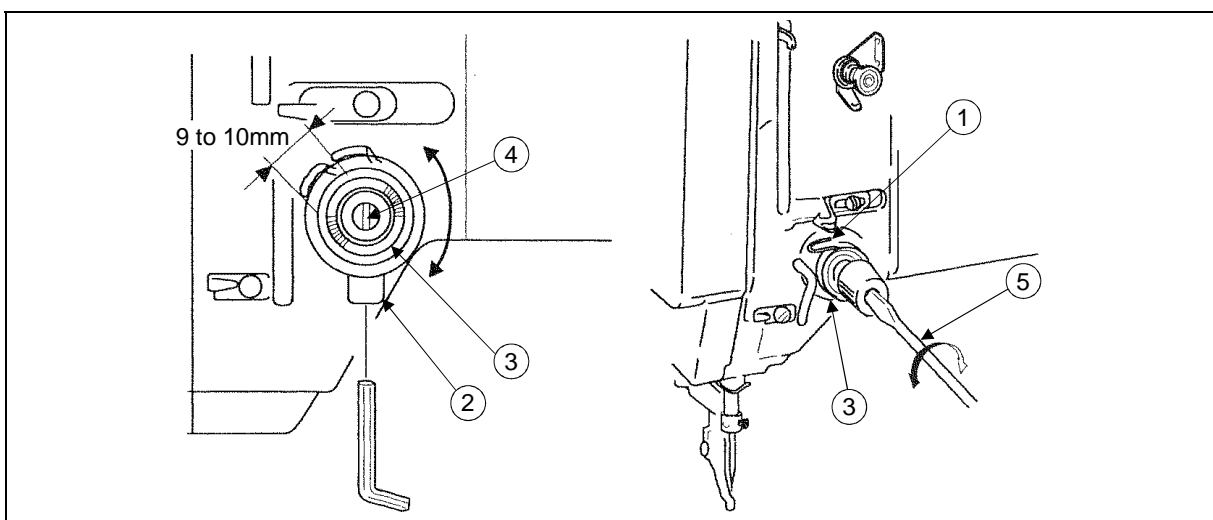

7-15 Adjustment of the synchronizer

NOTE a) When the sewing is finished, the arm timing mark **A** and the pulley timing mark **B** are matched with each other then, the sewing machine is stopped the running. This is the normal condition.

b) If these timing mark **A** and **B** get out of the matching more than 3mm, adjust the timing mark matching.



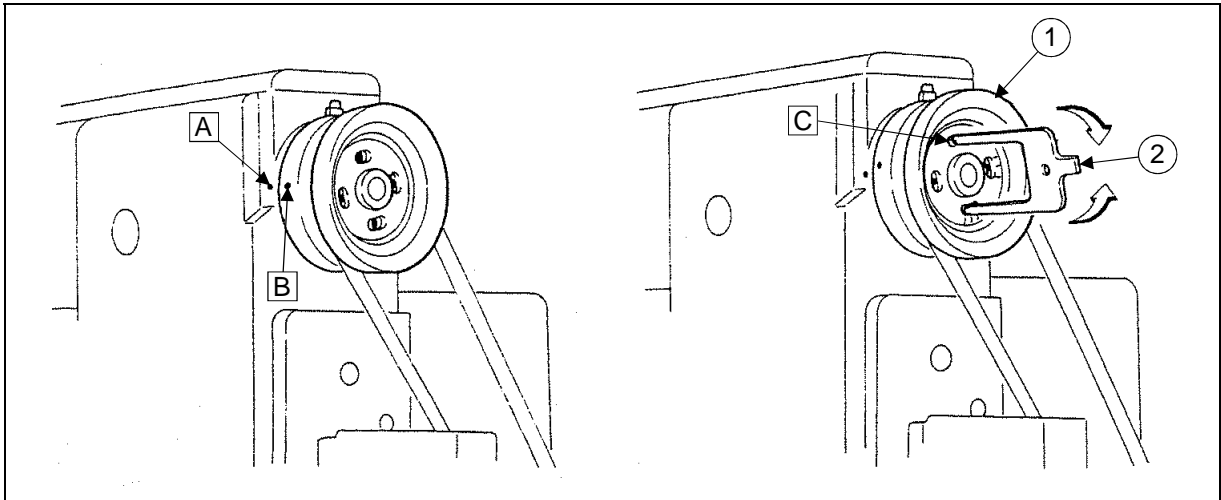

Hold the sewing machine pulley (No.1) by hand and insert the angle adjuster (No.2) into the hole **C** then, turn the angle adjuster (No.2). If turn the angle adjuster (No.2) to the clockwise, the pulley timing mark **B** comes down and if turn it to the counter clockwise, the pulley timing mark **B** goes up. The angle adjuster (No.2) is enclosed in the accessory box.

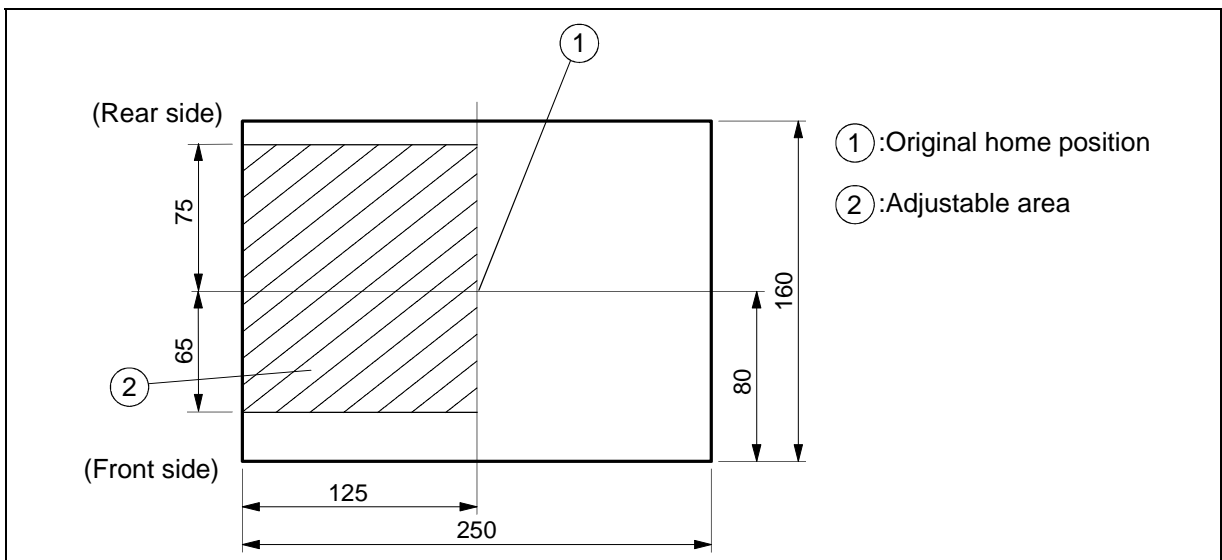

7-16 Adjustment of the mechanical home position

NOTE The mechanical home position (No.1) is fixed at the center of the sewing area when the sewing machine is shipped from the factory. However, it can be moved within the area covered with diagonal lines (No.2).

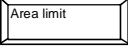

- 1) Turn the power switch ON and cancel the sewing area limit with the operation panel.
 - a) For this cancellation, press the  key at the normal mode condition, then MENU MODE is appeared.
Press the  key.
 - b) And press the  key.
 - c) If you select [ALC]=[ON], the sewing area limit control is canceled.
- 2) After the sewing area limit control is canceled, press the  key and the  key. Window is back to the standard mode.

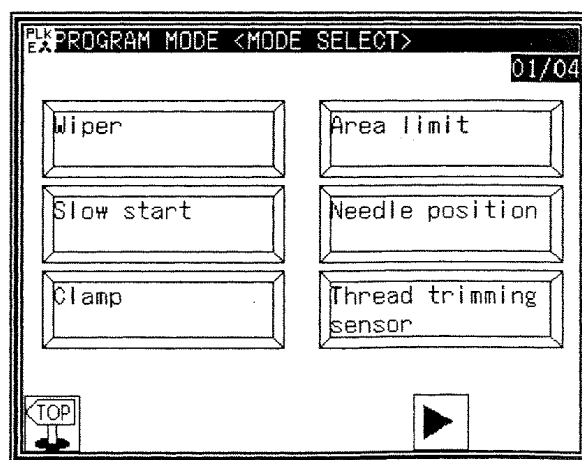
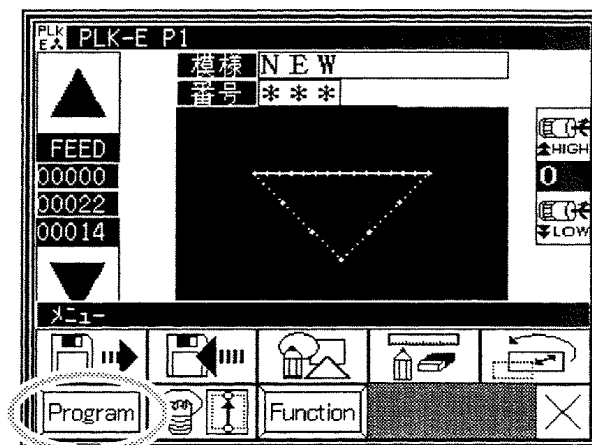

NOTE If do not cancel the sewing area limit, shifting the mechanical home position makes the effective sewing narrower than the original.

(Example) If shift the mechanical home position to the X direction 60mm, the Y direction 40mm without canceling the sewing area limit, the area covered with diagonal lines becomes invalid and the effective sewing area becomes narrower as a bold rectangle shown on the figure.

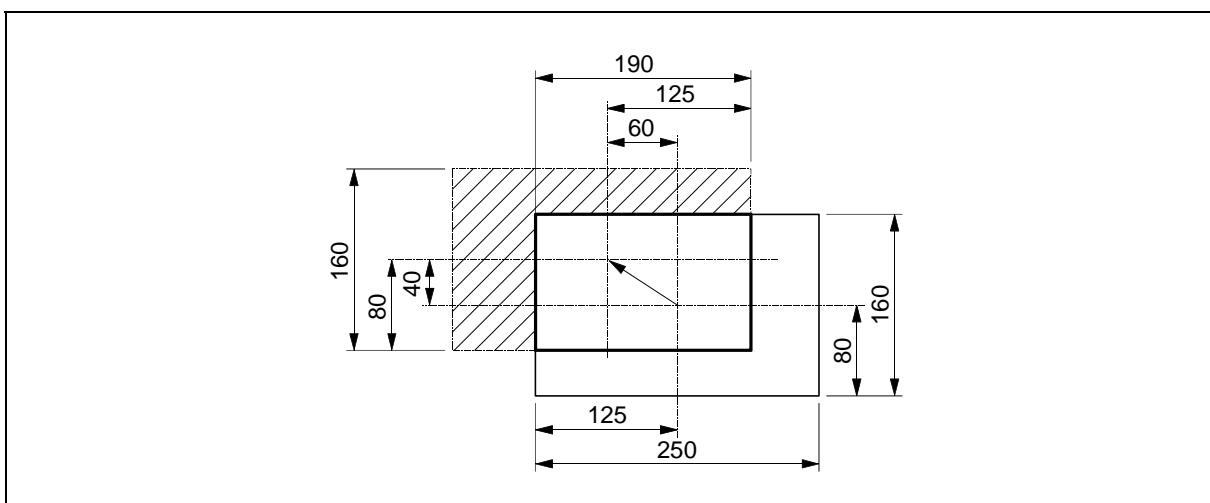

- 2) After the cancellation of the sewing area limit, once, turn the power switch OFF.

7-16-1 Shifting the mechanical home position to the X direction

- 1) Remove the X-Y cover (right), (left) and X cover.
- 2) Loosen the detector plate fix screws (2 pieces) (No.1). If move the detector plate (No.2) to the right, the mechanical home position is shifted to the left and if it is moved to the left, the mechanical home position is shifted to the right.
- 3) After the mechanical home position setting, tighten the detector plate fix screws (No.1) securely.
- 4) If the shift amount of home position by using this method enough. Please adjust by following procedure.
- 5) Remove the detector adapter fix screws (No.3).
- 6) Replace the detector adapter (No.4) to other position. In this case if move the detector adapter (No.4) to the right, the mechanical home position is moved to the right and if it is moved to the left, the mechanical home position is moved to the left.
- 7) After setting, tighten the detector adapter fix screws (No.3) securely.

NOTE When the original mechanical home position is shifted. Please check the clearance between the X detector plate and the X detector.

This clearance should be set within the range of 1.0 to 1.5mm.

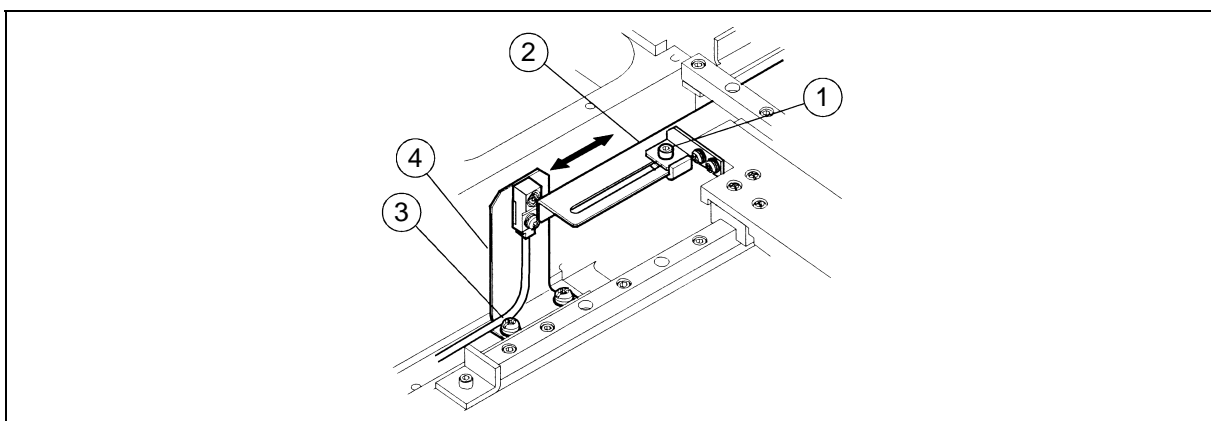

7-16-2 Shifting the mechanical home position to the Y direction

- 1) Loosen the Y-detector set screws (No.1).
- 2) If move the Y-detector (No.2) to the front, the mechanical home position is shifted to the backward. If it is moved to the backward, the mechanical home position is shifted to the front.
- 3) After the mechanical home position setting, tighten the screw (No.1) securely.

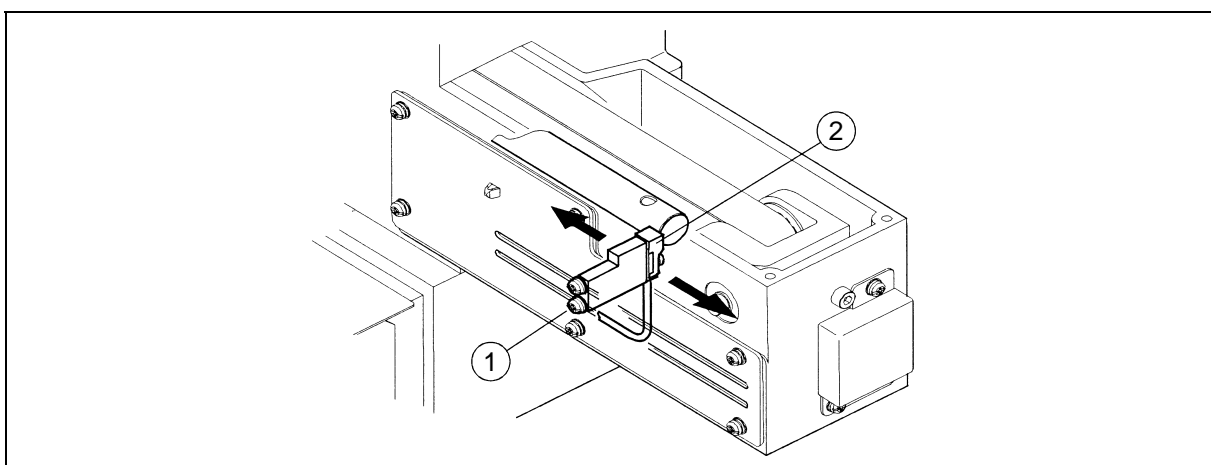

7-17 Adjustment of the X-Y timing belt tension

NOTE The proper condition of the X-Y timing belt tension is standing that they will not be got any yield even it is slightly pushed by hand.

7-17-1 Adjustment of the X timing belt tension

- 1) Remove the right X cover and the right X cover plate.
- 2) Loosen the set screw (No.2) of the bracket (No.1).
- 3) If the tighten the tension adjust screw (No.3), the X timing belt (No.4) tension will be increased.
- 4) After adjustment, tighten the set screw (No.2).

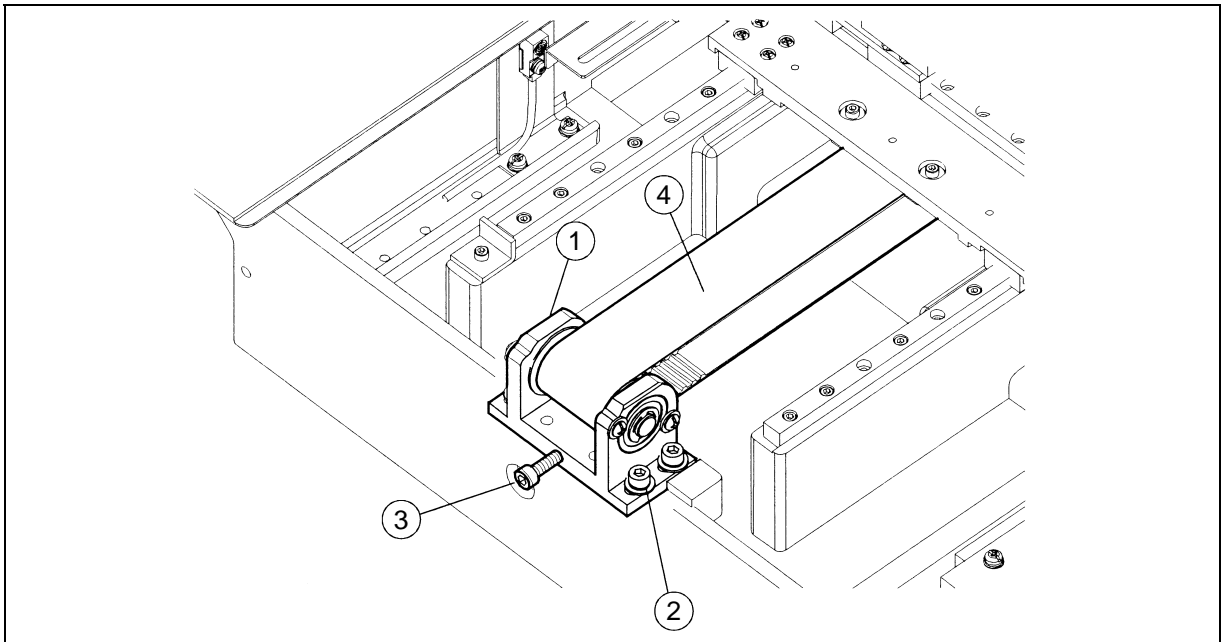

7-17-2 Adjustment of the Y timing belt tension

- 1) Loosen the bracket set screws (No.1).
- 2) If tighten the tension adjust screw (No.2). The Y timing belt tension will be increased.
- 3) After adjustment, tighten the bracket set screws (No.1) securely.

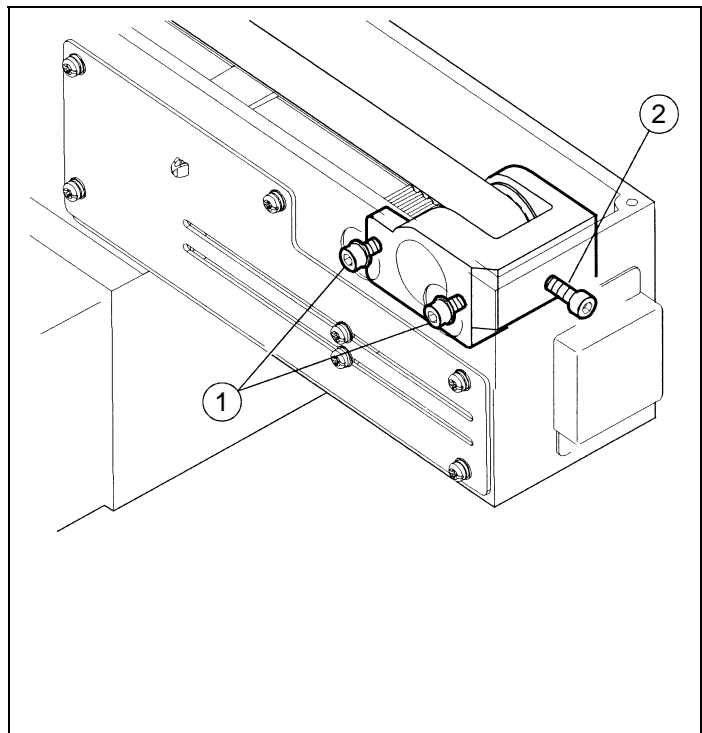

7-18 Adjustment of the V belt tension

NOTE After operated the sewing machine for a long period, the V belt tension becomes loose. Adjust the V belt tension periodically. The proper V belt tension is standing that it is bent about 10mm with the hand pressure of 1.0kg as it shown on the figure.

- 1) Turn the power switch OFF.
- 2) Remove the V belt covers.
- 3) Loosen two nuts (No.2,3) on the motor position adjust bolt (No.1).
- 4) Fix the motor (No.5) position with putting the tension to the V belt by its weight and firstly, tighten the upper nut (No.2) then secondly, tighten the lower nut (No.3).

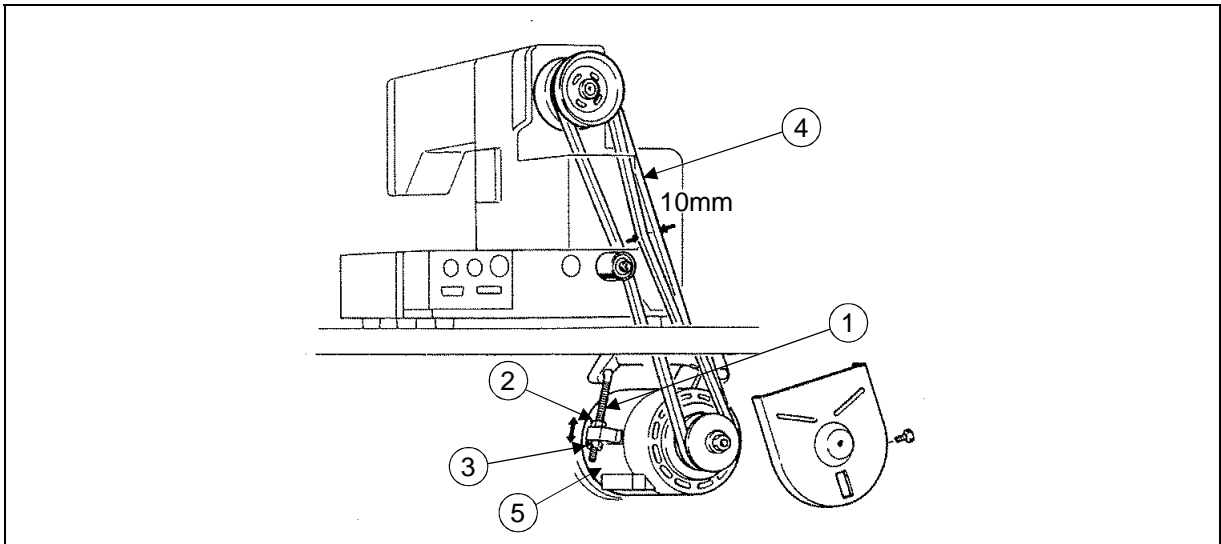

8. MAINTENANCE

CAUTION

- ★ Please make sure to turn the power switch always OFF when clean up the sewing machine.
- ★ Before or after the sewing operation, clean up the sewing machine and check the oil level in the oil tank.

8-1 Cleaning

- 1) Turn the power switch OFF.
- 2) Remove the dust and the thread waste sticking around the threading parts or the shuttle hook area.
- 3) Check the oil level in the oil tank. If the oil is under the red mark level supply the oil to be over the red mark level.

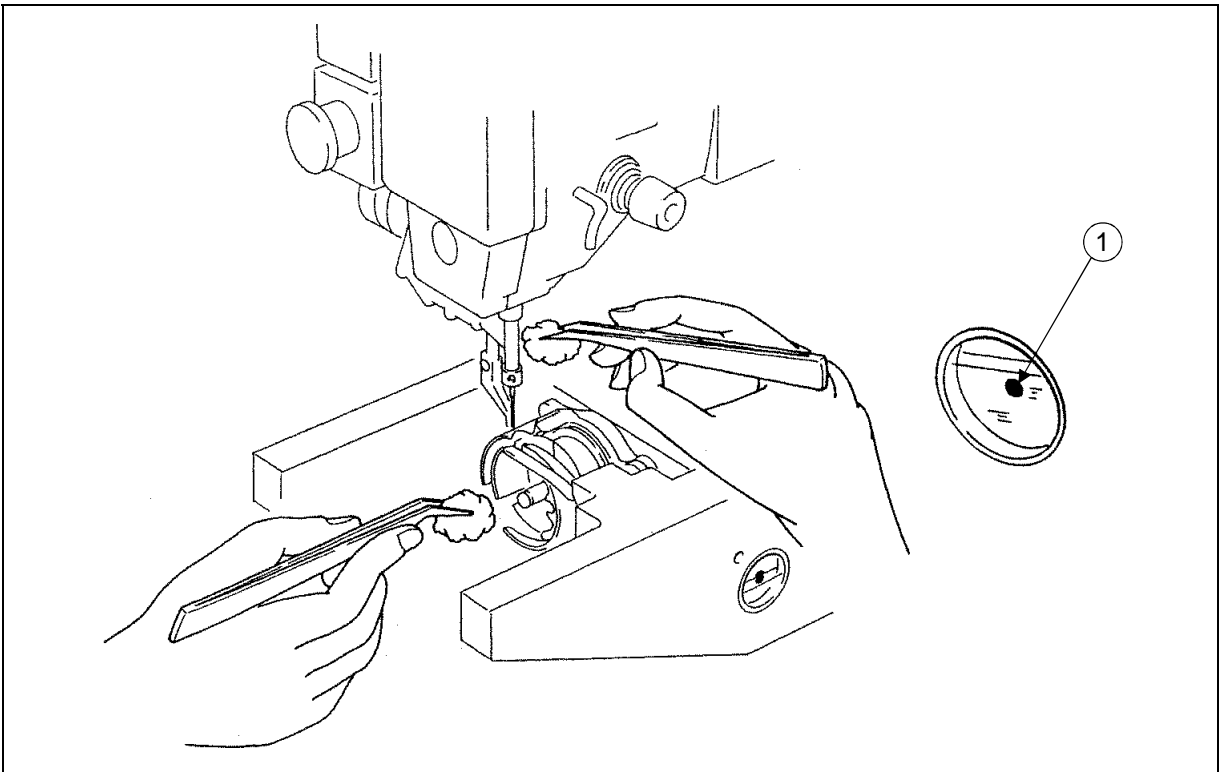

8-2 Disposing of oil waste

If the waste oil is full filled in the oil bottle (No.1), remove the oil bottle (No.1) then, dispose of the waste oil.

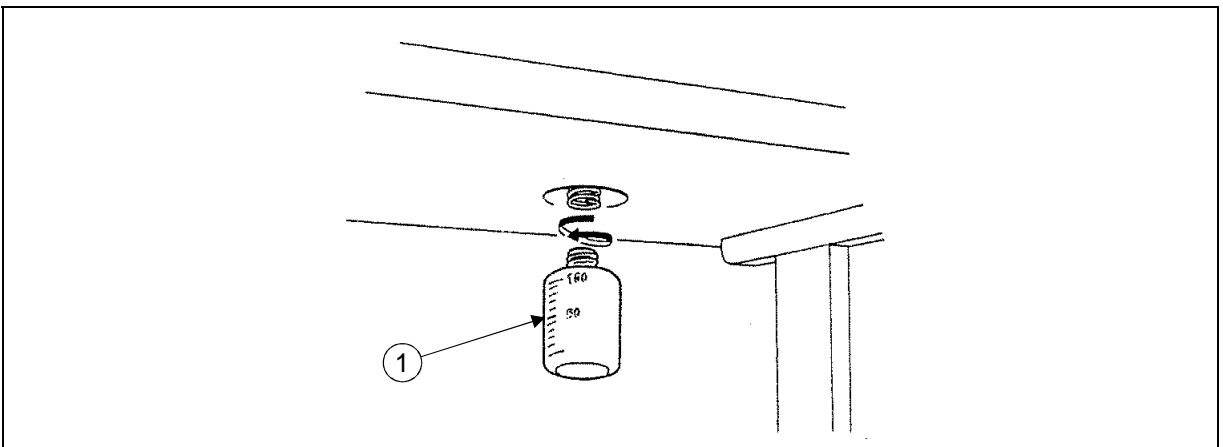

9. BAD SEWING CONDITION & ITS CAUSE AND REMEDY

NOTE Please fix the troubles during the sewing machine operation with referring to the following instructions.

Beside, if the trouble conditions are not coming under these classification, please contact the sewing machine dealers nearby.

Bad condition	Cause	Remedy	Ref. page & Item
1. Upper thread breakage often happens	Poor thread quality	Use better quality thread	—
	Tight upper thread tension	Adjust thread tension	P20-6-3-2)
	strong thread take up spring	Adjust thread take up spring properly	P37-7-14
	Upper thread is thicker than needle size	Change needle to suitable size	—
	Damages on rotating hook	Change them new ones or grind them with buffing wheel or grind stone	—
	Damages inside needle plate needle hole	Change it new one or grind it with buffing wheel	—
	Damages inside presser foot needle hole	Change it new one or grind it with buffing wheel	—
	Needle touches with presser foot needle hole	Move presser foot position	—
	Needle and rotating hook are not in proper timing	Adjust the timing	—
	Thread melts with needle heat	Slow down sewing speed	P19-4)
Use silicon oil		—	
Use needle cooler		—	
2. Upper thread is pulled out from needle	Thread tension discs are not opened at trimming	Adjust thread tension release	P36-7-10
	Thread take up spring swings too much	Adjust thread take up spring's swing stroke	P37-7-13
	Needle size is bigger than thread size	Change needle to suitable size	—
	Pre-tension is too tight	Adjust pre-tension	P37-7-11
	Thread guide is in wrong position	Adjust thread guide position properly	P36-4)
	Needle and rotating hook are in bad timing	Adjust the position properly	P22-7-2
	Trimmer timing is not correct	Adjust trimmer cam position	P33-7-9-2.6
		Adjust movable knife position	P35-7-9-2.7
3. Skip stitch happens at start sewing	Too short bobbin thread by bobbin spinning at trimming	Use non racing spring with bobbin	—
	Bobbin thread tension is too tight	Loosen bobbin thread tension spring	P20-6-3-1)
	Thread tail from needle is very short after trimming	Decrease pre-tension	P37-7-11
		Adjust trimmer cam position	P33-7-9-2.6
		Adjust synchronizer position	P38-7-15
		Make thread take up swing stroke smaller	P37-7-13
		Advance thread tension release timing	Control unit
		Adjust thread guide position properly	P36-4)
Adjust the position properly	P22-7-2		

Bad condition	Cause	Remedy	Ref. page & Item
4. Thread tail from needle is too long after timing	Pre-tension is too loose	Make pre-tension tighter	P37-7-11
	Trimmer timing is delayed	Adjust trimmer cam position	P33-7-9-2.6
		Adjust synchronizer position	P38-7-15
	Upper thread tension release timing is too fast	Delay tension release timing	Control unit
5. Trimming is not functioned	Thread guide is in wrong position	Adjust thread guide position properly	P36-4)
	Trimmer function is canceled	Resume trimmer function	Control unit
	Fixed knife is dull	Change it new knife	P31-7-9-2.1
	Movable knife is in wrong position	Adjust movable knife position properly	P31-7-9-2.2
	Skip stitching happens at trimming	Fix skip stitching	P44-3
	Trimmer air cylinle is out of order	Change it new air cylinle	—
6. Skip stitching often happens	Trimmer timing is wrong	Adjust trimmer cam position	P33-7-9-2.6
	Needle and rotating hook clearance is too big	adjust synchronizer position	P38-7-15
		Adjust needle and rotating hook clearance properly	P22-7-2-8)
	Needle and rotating hook timing is not correct	Adjust needle and rotating hook timing properly	P22-7-2-7)
	Needle is bent	Change it new needle	—
Needle is in wrong position	Amend needle position	P21-7-1	
7. Stitch forming is loose	Stepping foot position is not correct	Adjust stepping foot position properly	P24-7-5
	Upper thread tension is not tight enough	Increase upper thread tension	P20-6-3-2)
	Thread tension regulator's discs are opened during sewing	Adjust tension regulator position properly	P37-7-13
		Adjust upper tension foot timing properly	P36-7-10
	Stepping foot position is not correct	Adjust stepping foot timing properly	P24-7-5
Stepping foot up and down timing is not proper	Adjust stepping foot timing properly	P27-7-5-3	
8. Sewing machine does not work eve start switch is turned ON	Cables wiring is disconnected	Connect all cables precisely	P9-3-12
	System software is not loaded	Load system software to control box	P13-5-1
	Emergency stop switch is kept ON	Release emergency stop switch lock	P17-6-1
	Start switch is out of order	Change it new start switch	—
9. Sewing machine runs idle at high speed when power switch is turned ON	Synchronizer cable is disconnected	Connect synchronizer cable precisely	Control unit
	Synchronizer is out of order	Change it new synchronizer	—
10. Work holder does not work	Work holder activate solenoid valve cable is disconnected	Connect the cable precisely	Control unit
	Work holder presser is not strong enough	Increase work holder presser	P29-7-8-1
	Work holder switch is out of order	Change it new work holder switch	—

Bad condition	Cause	Remedy	Ref. page & Item
11. Sewing pattern is distorted	X-Y table have a play	Adjust X-Y table sliding contact presser properly	—
	Work holder presser is not strong enough	Increase work holder presser	P29-7-8-1
	Sewing material weight is very heavy	Slow down sewing speed	P19-4)
		Slow down feeding speed	Control unit
		Select sewing material weight level at feeding	Control unit
X-Y timing belts are loose	Adjust X-Y timing belt tension properly	—	
12. Work holder does not stop at home position	X or Y detector cabled are disconnected	Connect X-Y cables precisely	—
	X-Y detectors are out of order (Red pilot lamps do not go on at home position)	Change them new detectors (Make sure red pilot lamps go on at home position)	—
	Detector and detector plate clearance is too big	Adjust the clearance properly	—
13. Work holder stops at not original home position	Detector or detector plate mounting is loose	Check set screws and tighten them securely	—
	Detector and detector plate clearance is bigger than standard	Adjust detector and detector plate clearance properly	—
	Home position correction function is in working	Cancel home position correction function	Control unit

APPENDIX

Table top and stand drawings.

Ref.1Table cut-out for PLK-E2516R machine

Ref.2Table and stand

NOTE Table top and stand must be produced refer to below drawings.

Recommendable measurements for original MITSUBISHI table top and stand are shown in the figures.

Ref.1 <Table cut-out for PLK-E2516R machine>

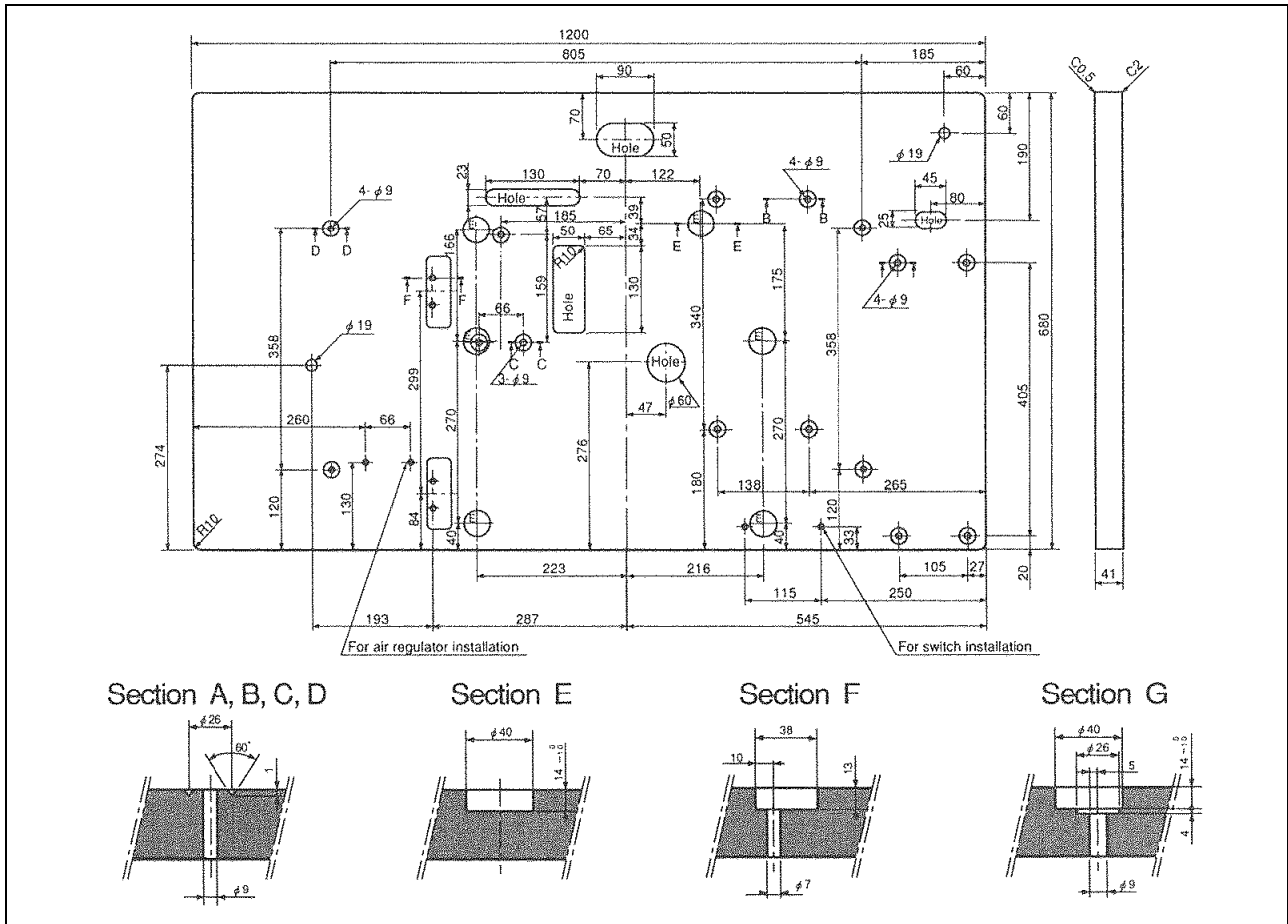

Ref.2 <Table and stand>

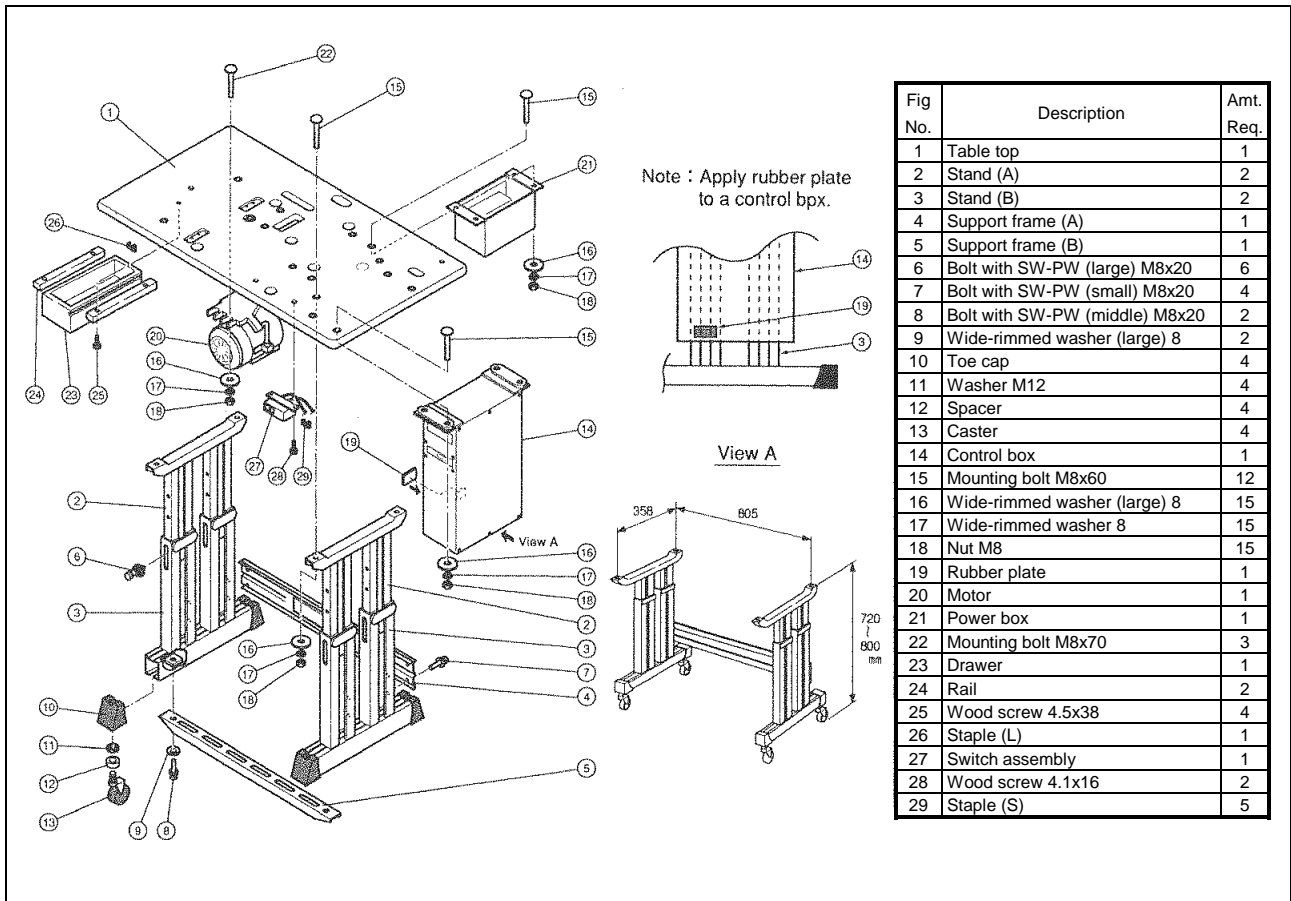



MITSUBISHI ELECTRIC CORPORATION

FACTORY AUTOMATION SYSTEM

OFFICE TOWER "Z" 14F 8-12 1chome, Harumi CHUO-KU, TOKYO 104-6212, JAPAN

Phone :+81-3-6221-6060 Fax :+81-3-6221-6076
