

FA ENERGY SOLUTION
e&eco-F@ctory

Changes for the Better

The Future of Factory Automation
for Productivity Enhancement and Total Cost Reduction



Energy Solution for Advanced Factories of the Future

e&ecoF@ctory

for a greener tomorrow



Announcing a solution that promotes further energy efficiency in factories.

To survive global competitions, further shop floor improvement is essential. FEMS* initiatives are also indispensable issues to manufacturing industries. Recognizing these two needs, Mitsubishi Electric has merged the e-F@ctory concept for optimizing factories through “visualization” and eco-Factory technologies that contribute to energy conservation through “visible management” of specific energy consumption, to create a new FA energy solution. To deliver enhanced productivity and total cost reduction through total command of energy information, we present to you e&eco-F@ctory.

*FEMS: Factory Energy Management System

The merging of e-F@ctory and eco-Factory is essentially the merging of productivity improvement through “visualization” of the manufacturing floor and energy conservation through “visible management” of energy.

Solution for Advanced Factories of the Future

e-F@ctory

【 Control and network technologies 】

e-F@ctory promises enhanced productivity. It makes full use of leading-edge control technologies and network technologies to “visualize” production information, including quantitative and qualitative production data and equipment information, and links production equipment to higher manufacturing execution systems to allow production information to be incorporated into production plans and be utilized to ensure quality traceability.

Proposal for Aggressive Energy Conservation

eco-Factory

【 Power receiving & distribution and measuring technologies 】

eco-Factory allows “visible management” of power usage through the introduction of measuring equipment and technologies that support energy conservation efforts by meticulously measuring power usage. It also promotes the effective installation of inverters and other energy-saving devices to not only eliminate wastefulness and surges in energy consumption but to reduce overall power usage.

Mitsubishi Electric's New FA Energy Solution

e&ecoF@ctory

Measure
Energy Usage

Visualize
Energy Usage

Reduce
Energy Usage

Manage
Energy Usage

Achieve productivity enhancement and total cost reduction through effective utilization of energy information.



Production equipment in factories are responsible for a particularly large percentage of energy consumption in manufacturing industries. For proper assessment of energy usage, precise measurements and the installation of numerous measurement points along the path from the power-receiving end to production equipment are required. A new indicator of factory optimization should also be established based on the amount of energy consumption per product, or in other words, on specific energy consumption.

As our solution, we have merged the control and network technologies that we have cultivated in the FA equipment sector with measuring technologies we have developed through energy conservation activities in the power receiving and distribution sector.

e&eco-F@ctory will simultaneously deliver productivity enhancement and total cost reduction through effective utilization of energy information.



Production efficiency measures and energy efficiency measures essentially both aim at achieving the same result.

Production efficiency and energy efficiency in factories essentially both aim at achieving the same goal of total cost reduction. In no way do they conflict with each other.

Mitsubishi Electric's e&eco-F@ctory is an FA energy solution based on a new concept of realizing both production efficiency and energy efficiency.

It brings large advantages to factories from two perspectives.



Advantages

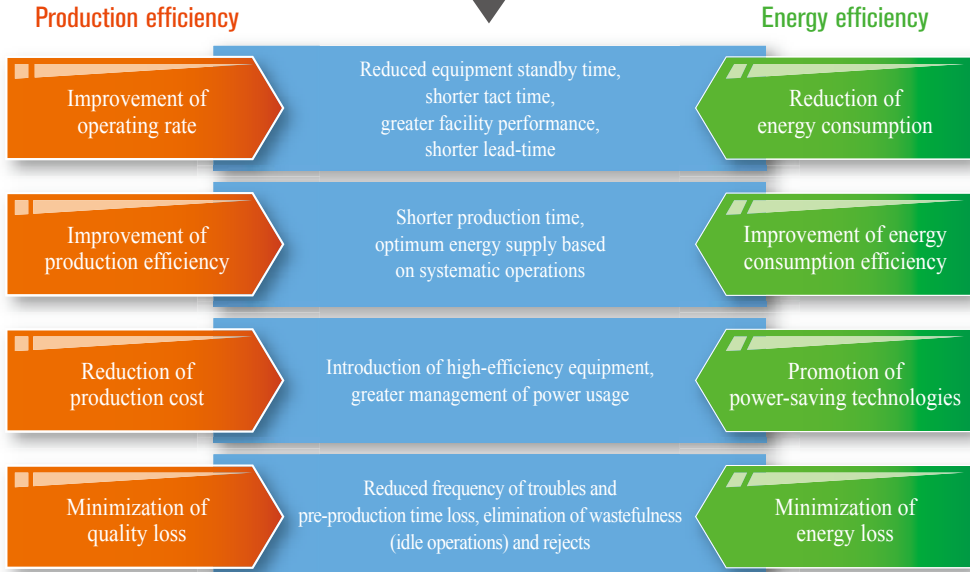

The e&eco-F@ctory concept is made possible by Mitsubishi Electric's strong expertise in FA and power distribution/control technologies.

We provide a wide lineup of FA equipment such as PLCs, HMIs, AC servos, and inverters, and power distribution and control equipment such as energy measuring meters and breakers.

We have also developed network devices that connect these components, and have consistently enhanced their performance. e&eco-F@ctory brings these technologies together to deliver an advanced solution that maximizes each of their strengths.

Measure, visualize, reduce, and manage – these are the steps to energy efficiency.

Do you have worries about the cost of energy in your plant?

If you do, it is important that you properly manage the specific energy consumption of each production equipment by making four improvements: (1) measure energy usage, (2) visualize energy usage, (3) reduce energy usage, and (4) manage energy usage.

Adopting a Just-In-Time approach to energy is also important to supply the necessary amount of energy to the necessary place at the necessary time.

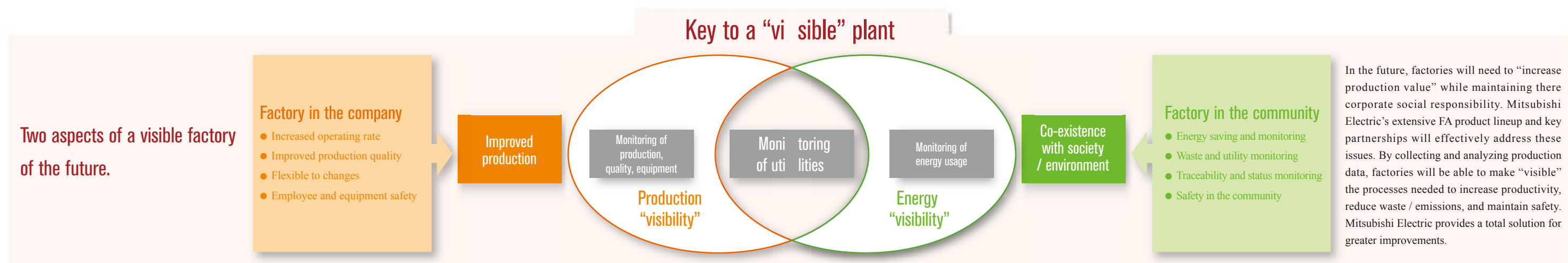
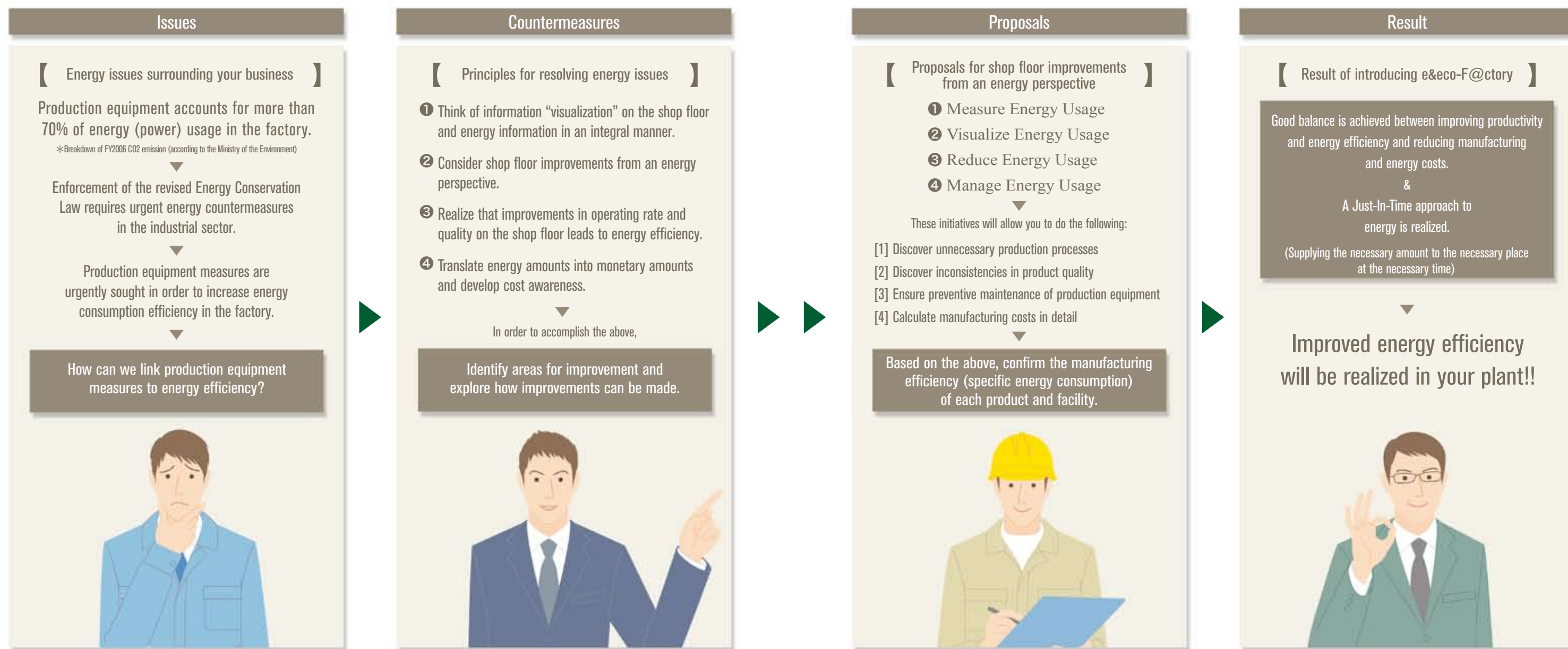

e&eco-F@ctory realizes factory-wide optimization through effective utilization of energy information.

Transforming a factory into an e&eco-F@ctory means optimizing the factory from an energy perspective. In an e&eco-F@ctory, production and energy information is "visualized" and linked together for thorough energy management. Furthermore, the different situations of energy use by different production lines are accurately assessed and their energy use is analyzed to ensure factory-wide energy optimization.

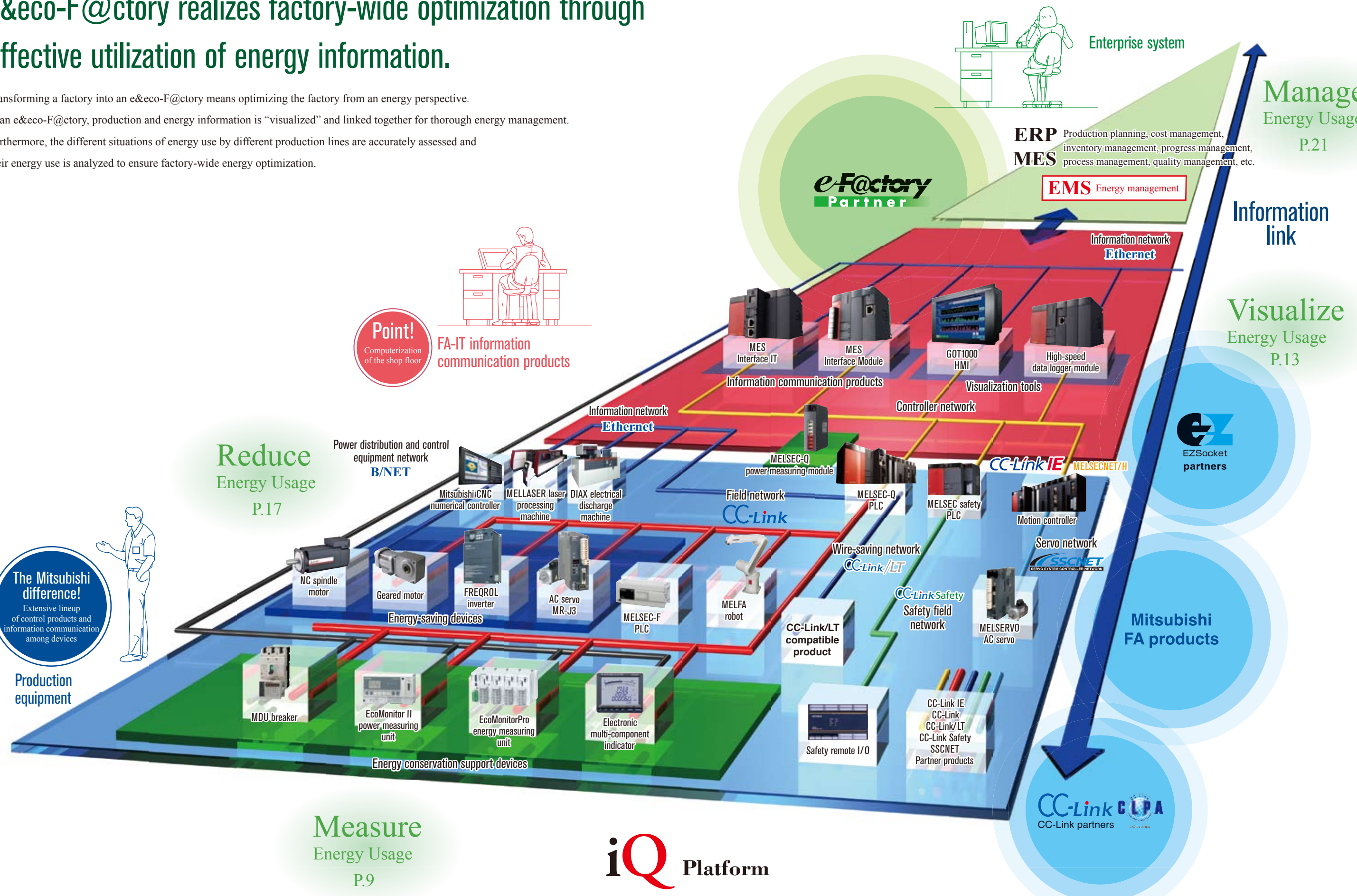

Point!
Computerization of the shop floor

FA-IT information communication products

Reduce Energy Usage P.17

The Mitsubishi difference!
Extensive lineup of control products and information communication among devices

Production equipment

Measure Energy Usage P.9

iQ Platform

CC-Link CLPA
CC-Link partners



Measure Energy Usage

Once you have detailed measurements for each device and piece of equipment, the way to increased productivity is clear.

The important thing to comprehensively “visualize energy” is, of course, to measure the amounts of energy being used in the shop floor in real time and collate the data, but also to keep an accurate grasp of specific energy consumption, with linkage to production volumes and other manufacturing information. e&eco-F@ctory aims to improve equipment working efficiency through detailed work analysis. It measures the specific energy consumption by production equipment and devices for every takt time, every product type, and every process. It links to work monitoring of production lines, preventive maintenance of equipment, and improved productivity.

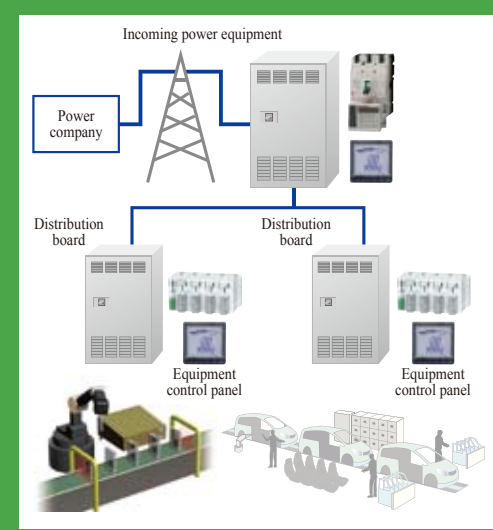

Slots directly into the PLC for simple measurement of diverse energy information!

■ MELSEC-Q Series power measuring module

Meets Energy-Saving measurement needs

I want to monitor the power used by each piece of equipment, for detailed energy-saving monitoring.

Meets Short-Term measurement needs

I want a fast measurement cycle to measure short-term loads.

Meets Quality control needs

I want to detect power supply irregularities in manufacturing equipment to control product quality.

Meets Preventive maintenance needs

I want to detect power and current used by manufacturing equipment and prevent sudden failures.

Meets Simple installation needs

I want simple and smooth installation, with no program for power measurement.



MELSEC Q series

These are key e&eco-F@ctory products, achieving fusion between production and quality information, and energy information.

MELSEC-Q, a constant innovator in the production workplace, launches a new power measuring module. This unit makes it easy to measure current, voltage, power, power factor, effective power consumption and other information, integrating production and quality information with energy information, and leading to improved productivity, energy saving, and preventive maintenance. And, it slots directly into the PLC, saving space, wiring, and cost. It enables energy measurement for each piece of production equipment, preventive equipment maintenance based on realtime measurement, and the use of quality control indices linked to manufacturing information.



Slots directly into the PLC!

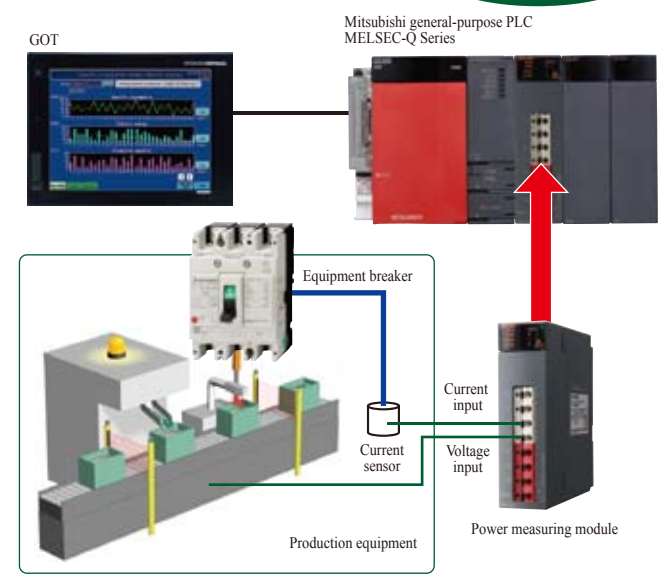

Slots directly into the PLC!
The power measuring module is directly attached to the PLC, so there is no need to install any other instruments or connect wiring. There is no need for any major system construction either, so it also saves space.

Measure energy consumption simply
Read the signal from the current sensor on the device breaker, to measure energy consumed by the device. It's easy to grasp power consumption for each PLC unit and manage the specific energy consumption for each individual device.

Easy comparison of power consumption
Power can be measured only when a specific output signal is on. Power over a period can be measured at two points, to find the standby power consumed while idling or compare power consumed over a certain period.

Grasp the energy consumption status of a device
Record the maximum and minimum values of demand current, voltage, demand power and power factor for each device. Equalization of energy consumption is supported, to identify devices and times of high energy consumption.

Quickly catch abnormal device status
Set two measurement factors and monitor their upper and lower limit values. That makes it possible to quickly catch abnormal device status, and to find devices which are using large amounts of energy.

This measuring unit is easy to attach to the equipment or circuit to be measured.

■ EcoMonitorPro : power measuring unit

The package and flexible concept and the combination with split current sensors makes this energy measuring unit easy to attach to the equipment or circuit to be measured.



Eco Monitor Pro

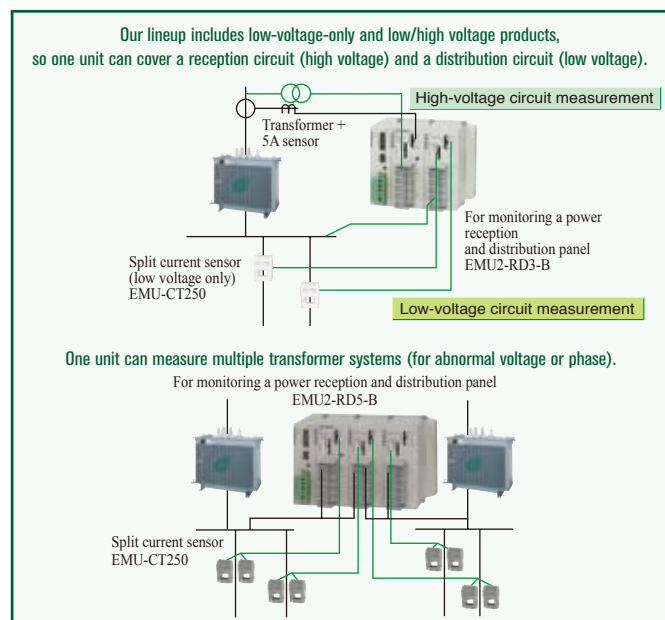

Flexible setting of measurement parameters

One unit can measure multiple transformer systems (for abnormal voltage or phase), and the necessary measurement parameters can be set for each circuit. The use of a relay system means that sensor cables can be adjusted to the right length when attached, for economical and waste-free wiring. Modules for CC-Link communications, B/NET transfer and LONWORKS communications can be retrofitted in cassette form to configure future systems.

Wide lineup of packages

Products for 1, 3, 5 or 7 circuits are packaged in our lineup (products for four wire, three phase wiring are for two or four circuits). You can devise waste-free system configurations. We also offer pulse emitters (single circuit) and power dip detectors, which are convenient for specifications that are built into machinery.

Extensive functions and ease of use support energy-saving measurement monitoring.

■ Electronic multimeter

Further expanded functions for measurement monitoring, display, output, communications and operation.

This meter has functions beyond those of a regular meter, and is still easy to use.

Advanced functions and ease of use support all kinds of measurement monitoring systems and energy-saving measurement monitoring systems.



Clearly legible screen

Four-range display, with three digital and one analog range. The digital display is the same large size for the upper, middle and lower ranges. Its a clearly legible LCD screen.

Helps to save board space

One instrument can read and display multiple parameters, such as current, voltage and power consumption, so it can save a large amount of space, compared to conventional mechanical instruments.

A rich lineup for specific applications, including models with transmission functions

Our abundant lineup includes products for specific functions, such as models with ground fault current monitoring, current meter relays, high-frequency meter relays, zero-phase voltmeters, and more, as well as networked models with CC-Link communications and B/NET transmission, to meet customer needs.

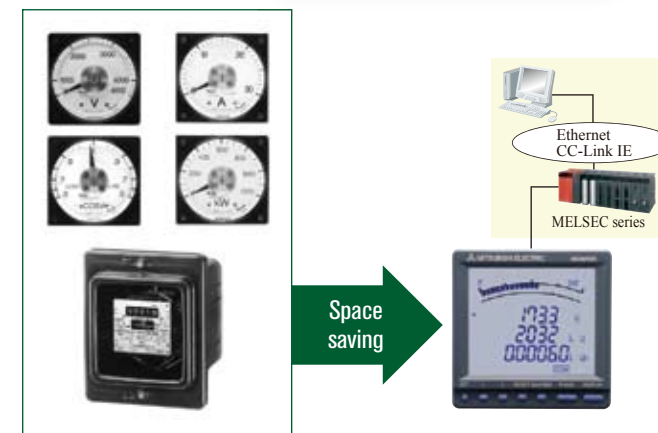

Diverse functions in a small body assist detailed energy-saving management.

■ MDU Breaker

This multifunction electronic breaker has a built-in measuring and display unit that measures circuit information and displays it digitally.

Our lineup of MDU-equipped no-fuse breakers, ground fault breakers and ground fault alarm breakers in the rated 50-80A range support detailed energy management and our customers' energy-saving activities.



MDU BREAKER

From energy saving to preventive maintenance

If the breaker trips, the cause of the incident and the current involved are stored on flash memory. That makes it quick to identify the cause and restore the system. If the breaker also has networking functions (CC-LINK communications, B/NET transmission), the times of peak values can be logged, which helps to identify times of peak power usage.

Saves wiring, construction and space

The breaker is a single unit together with the measurement VT/CT and the measurement display unit, which helps to save wiring, construction and space.

Easier to use

Our 250A frame products are even easier to use than before, with adjustable rated current, so it is simple to change the setting when loads increase, just by turning a dial.

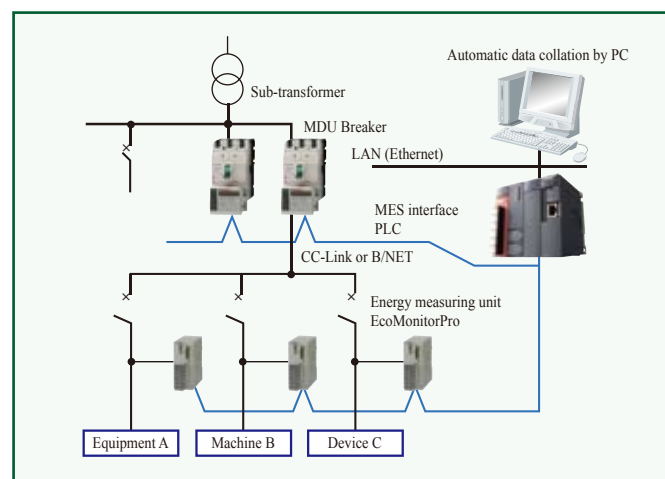

Energy information is also measured to promote the “visualization” of the shop floor.

■ GOT1000 : HMI

The GOT1000 human-machine interface (HMI) for production lines incorporates MES Interface functions. It collects and displays electric power, water, air, gas, and fuel measurement data from a MELSEC-Q Series measuring module via CC-Link. It not only monitors energy consumption in real time, but it also facilitates energy management, quality management, and monitoring of equipment operations in accordance with shop floor information. Moreover, the functions of different types of monitors connected to PLCs, motion controllers, and CNCs, respectively, can be integrated in GOT1000.

Monitors energy consumption in real time

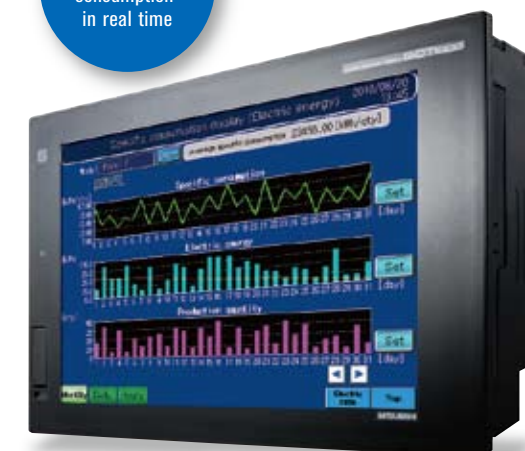

GRAPHIC OPERATION TERMINAL
GOT1000

For energy management, quality management, and equipment monitoring

- Monitors energy consumption in real time.
- Facilitates energy management, quality management, and monitoring of equipment operations in accordance with shop floor information.
- Computerizes information from existing equipment and equipment other than MELSEC PLCs.
- Supports workers by providing a connection to a barcode reader and display documents.
- Offers extensive information management functions that can only be offered by an HMI.

Visualize Energy Usage

The “visualization” of energy and production information serves as an indicator of improvement.

Improving productivity efficiency by managing specific energy consumption is a priority issue on the shop floor. The key to achieving this lies in linking energy information obtained from each production equipment and device with production information from the shop floor, and assessing production efficiency and manufacturing cost of each part, product, equipment, and work process from an energy perspective, by utilizing production energy efficiency as an indicator of improvement. e&eco-F@ctory utilizes FA-IT information communication products and HMIs to communicate production equipment information, so that wasteful and inconsistent work processes can be discovered from an energy perspective and effectively improved.

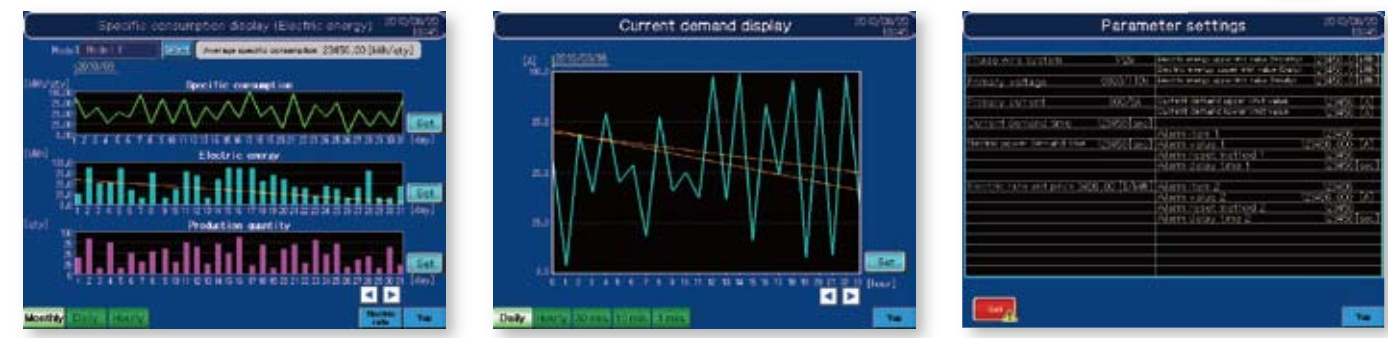
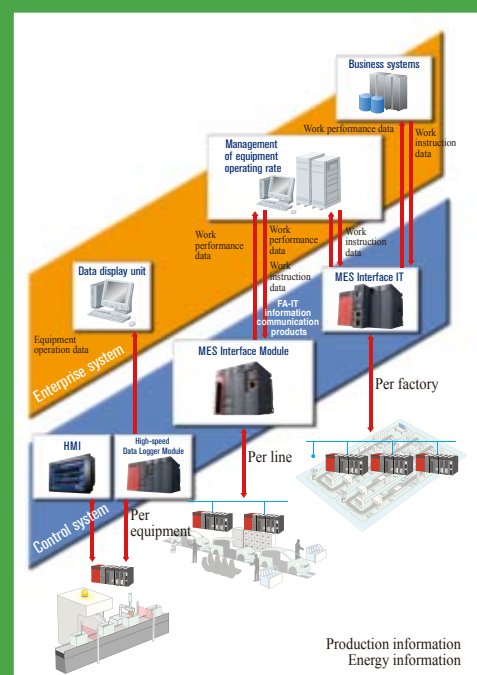

■Screen showing specific energy consumption (electricity rates) ■Screen showing demand electric current ■Screen showing parameter settings for a Q Series power measuring unit

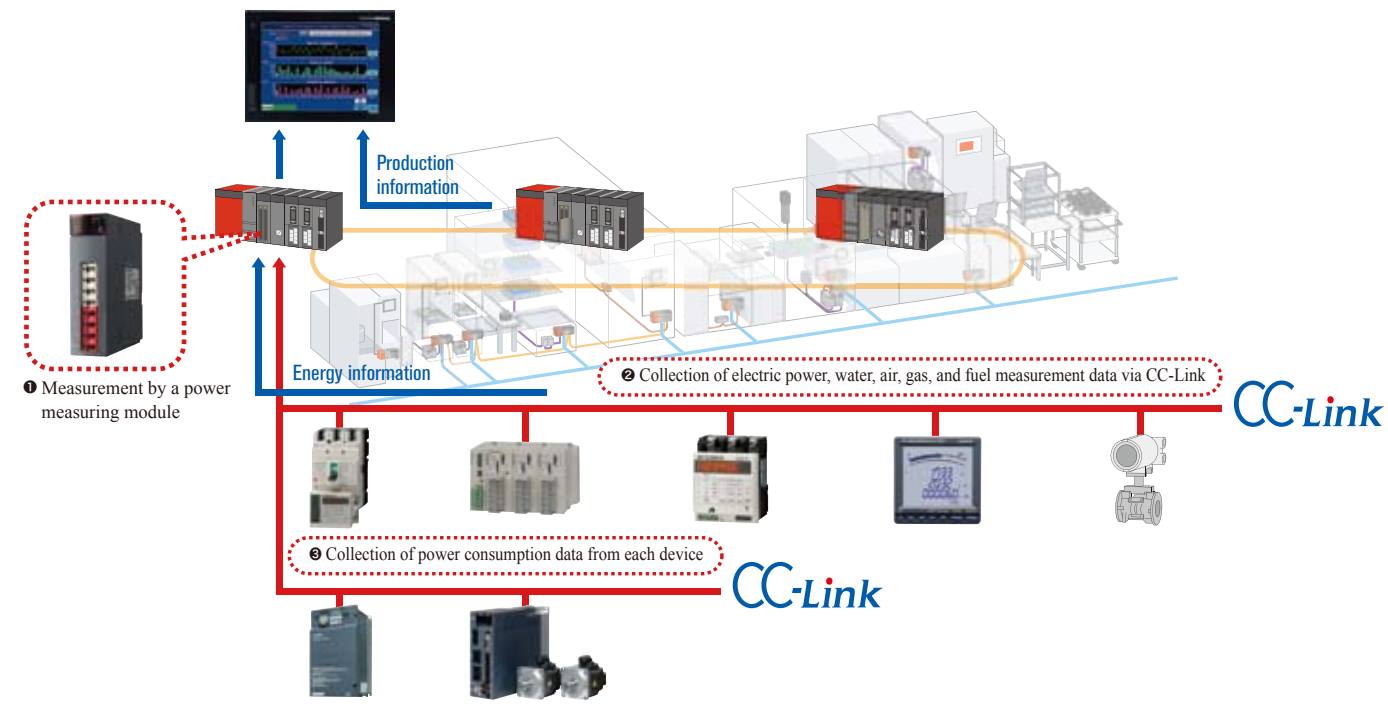

Electric power and currents are logged to monitor energy and keep daily records of specific energy consumption.

High-speed Data Logger Module

Mitsubishi's high-speed, simple, and low-cost High-speed Data Logger Module provides accurate data logging that transcends the conventional data logging framework.

For example, it can be used to monitor electric power and currents obtained from a MELSEC-Q Series power measuring unit or to create daily reports on specific energy consumption. By accumulating various data from production processes, the High-speed Data Logger Module not only contributes to reducing energy cost, but also to optimizing systems that are necessary for improving production quality and building an efficient production site.



Automatic creation of Excel files from logging data

Charts and reports are automatically generated from logging data, simply by transferring Excel layout files to the High-speed Data Logger Module. This function can be used, for example, to monitor electric power and currents obtained from a MELSEC-Q Series power measuring unit or to create daily reports on specific energy consumption.

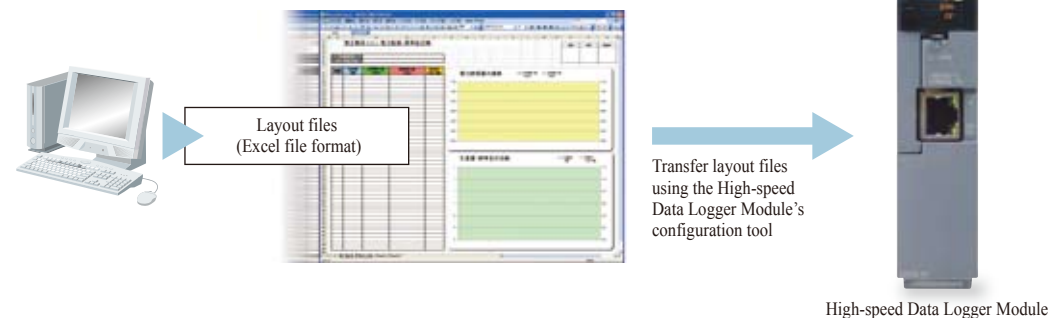

Daily records, charts, reports, and a variety of other documents that include visual aids can be created automatically.

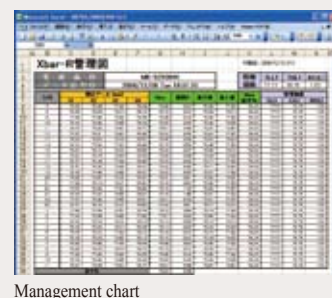

Synchronization with a program scan sequence

Energy measurements and other such data can be logged at high speed and with precision in synchronization with a program scan sequence, the smallest unit of time that can be controlled. Using this function, collected data can be analyzed for detailed operational analysis, as even the slightest change in control data is detected and logged.

Prompt analysis of problems in the event of trouble

The High-speed Data Logger Module allows the user to narrow down and extract only specific data, such as on specific energy consumption, that is saved around the time of a pre-defined trigger occurrence. This function is helpful in promptly identifying the cause of an error and implementing solutions for quick restoration of operations. Additionally, potential causes of errors can be established as triggers, so that the High-speed Data Logger Module only saves the data logged immediately before and after the occurrence of those triggers.

PLCs are directly linked to the MES for efficient collection and management of energy information.

MES Interface Module for MELSEC-Q Series PLCs

The MES Interface Module for MELSEC-Q Series PLCs automatically generates data to be sent to the MES (Manufacturing Execution System) in SQL. Configuration is easy, as PLCs can be connected directly to the MES without gateway PCs or processing programs that were conventionally required. The seamless network allows collection and management of all types of information inside a factory, including energy information and information regarding production processes, equipment operations, and quality. The MES Interface Module creates an information link between production equipment and MES easily, and at low cost.



Collect and manage all types of information inside the factory, such as on production processes, equipment operations, quality, and energy through a seamless network.

Information from even the most peripheral equipment can be collected via a field network.

Machine tools and equipment incorporating a non-Mitsubishi PLC can also be easily connected using an open network.

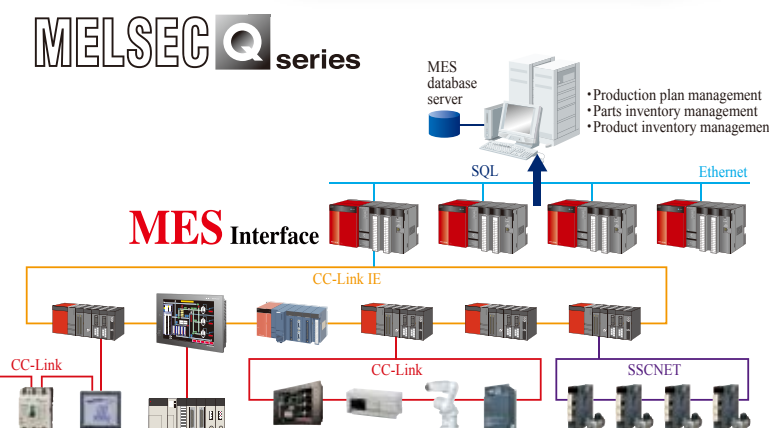

Greater compatibility with diverse platforms and databases ensures direct connections between the shop floor and information systems.

MES Interface IT for MELSEC-Q PLCs

MES Interface IT was developed to integrate shop floor operations into management strategies. By connecting the shop floor to information systems directly without the use of any programs, MES Interface IT allows effective management of information from production lines and facilitates business management.

- Eliminates the need for communication gateway PCs or programs and provides an efficient information collection system at low cost.
- Supports a wide range of communication protocols to ensure efficient connections with information systems and to deliver compatibility even with large-scale IT platforms.
- Allows easy set-up using simple tools and easy mapping of data collected by PLCs and information systems.

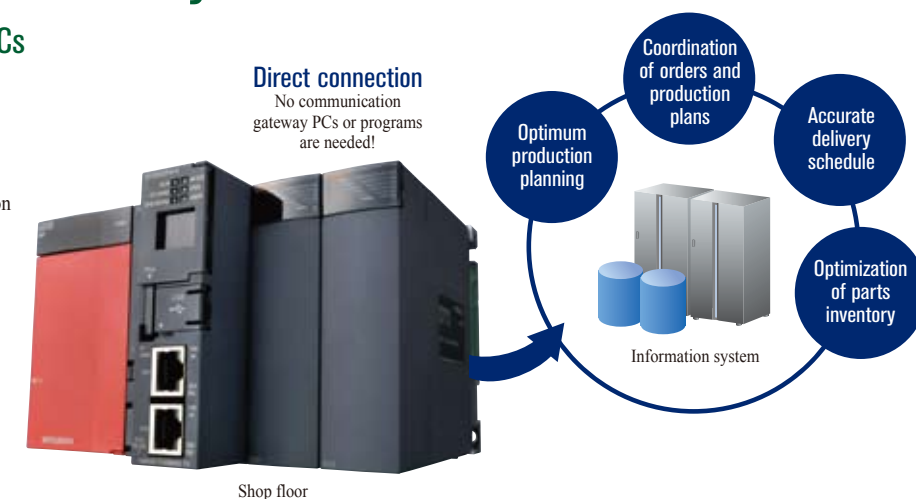

Main differences between MES Interface and MES Interface IT

Item	MES Interface	MES Interface IT
Compatible databases	MS SQL, MS Access, Oracle, Wonderware Historian	DB2, MS SQL, Oracle
Message communication and other communication programs	—	Message communication: WMQ, JMS, MSMQ Other communication programs: TCP, e-Mail
IT platforms	Windows	UNIX, LINUX, Windows (compatible with all types of IT platforms)

Evolution of the inverter for fan and pump applications, energy savings for buildings and factories as a whole.

■ FREQROL F700 series : Energy saving inverter

As the need grows to conserve energy, inverters capable of delivering significant energy savings have become indispensable, especially for air conditioning equipment, fans and pumps that have to run continuously.

The FREQROL-F700 Series advances energy conservation technology, using optimum excitation control to reduce energy consumption by up to about 12%. It offers a full lineup, from small capacity (0.75 kW) to large (560 kW) inverters with excellent drive control, ease of maintenance, environmental durability and operability.

More Energy Savings

Upgrade of the renowned Optimum Excitation Control

•Achieved a higher level of energy savings during acc./dec. to say nothing of during constant speed.

Ex. of Blower Operation Characteristics

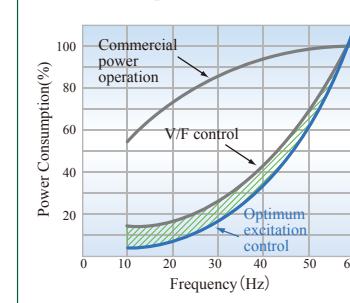

Ratio of Motor Power Consumption during Acc./Dec.

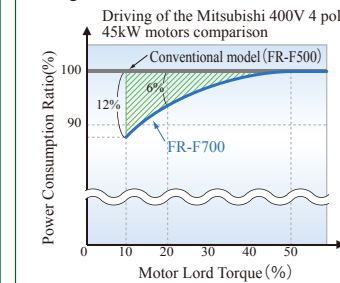

The effect of energy savings is obvious

•The effect of energy savings can be confirmed using the operation panel, output terminal (FM, AM terminal) and via networks with the newly developed energy saving monitor.

Energy Saving Monitor List

Power saving monitor (kW)	Power saving rate average value (%)
Power saving rate (%)	Power saving charge average value (\$)
Power saving amount (kWh)	Annual power saving amount (kWh)
Power saving amount charge (\$)	Annual power saving amount charge (\$)
Power saving average value (kW)	

Ideal for Fans and Pumps

Adjustable 5 points V/F

•Possible to set the torque pattern that is optimum for the machine's characteristic
•Possible to expect even more energy savings with optimum excitation control and optimum V/F pattern working together

Enhanced PID function

•Energy savings in low speed region ... PID shutoff (sleep control) function
•Shorter PID startup time ... PID automatic switchover function
•Monitor of set point/measured value/deviation possible ... PID monitor
•Convenient for HVAC usage ... forward/reverse operation switchover is simple with an external signal
•Corresponds to a wide range of detectors ... set point and measured value for PID input can either be voltage (0 to 5V/0 to 10 V) or current (4 to 20mA)



FREQROL-F700

Ex. of Power Savings Monitor Display

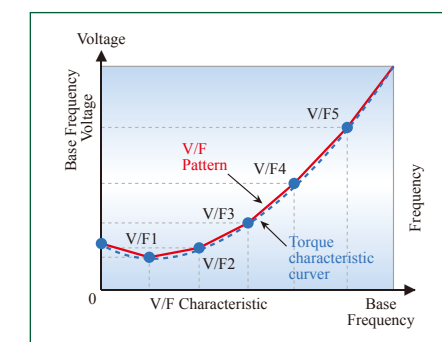

Reduce Energy Usage

Overall energy efficiency starts with energy-efficient equipment.

Even using the latest "visible" technology and taking meticulous measurements of your shop floor's energy information will not boost your energy efficiency if your production equipment itself is inefficient. Start by implementing equipment built for efficiency and energy conservation, and you'll raise your production efficiency while lowering energy consumption.

Then give your equipment higher performance and you can optimize your plant in total.

e&eco-F@ctory takes advantage of Mitsubishi Electric's strong lineup of inverters, motors and other drive products to point out ways to lift your equipment's energy efficiency and get your shop floor running optimally overall.

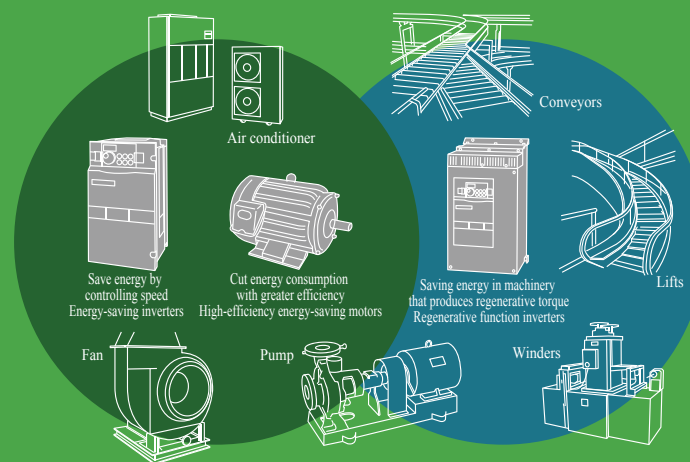

All-in-One Inverter with Built-in Power Regeneration.

■ FREQROL-A701 : General-Purpose Inverter

The FR-A701 Series adds power regeneration to Mitsubishi's established FR-A700 Series of high-function general-purpose inverters to achieve great braking capacity. Because the power regeneration function is built into the inverter, it dispenses with the complicated and cumbersome wiring that was previously necessary and also saves space. The energy conservation effect is apparent, since the amount of energy regenerated can be checked by the regeneration monitor. This helps save energy in machinery and facilities that produce regenerative torque, such as lifts, cranes, centrifuges and winders.



FREQROL-A701

Energy conservation with power regeneration function

You can reduce your total costs compared to a combination of conventional systems (inverter + power regeneration converter + AC reactor). And because regenerative energy is returned to the power source, you reap the energy savings. The actual amount of energy regenerated can be confirmed by checking a new function, the power regeneration monitor.

Requires less wiring and space

Compared to a conventional setup with a common converter that is placed separately, this can reduce wiring in the main circuit by about 60% and the equipment footprint by about 40%. And there's no need to go to the trouble of picking a particular brake unit, because the brake circuit is built in. (In the case of 200 V, 7.5 k.)

Application example

Vertical parking structure

Ceiling crane

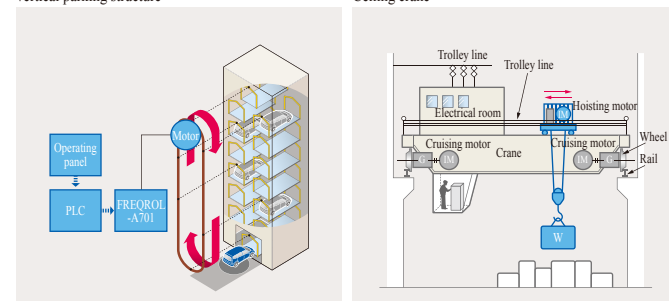

What is power regeneration?

Power regeneration is an action that yields great braking force by returning regenerative energy from the motor to the power source.

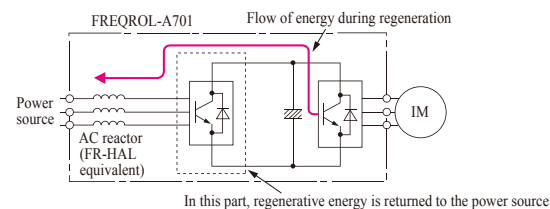

Regenerative Energy for Deep Energy Savings.

■ MR-J3-DU Series : Servo Amplifier

The MR-J3-DU Series servo amplifier creates significant energy savings using a common bus with the power regeneration converter. The regenerative energy of deceleration, which would have been consumed as heat in the past, is returned to the power source. So regenerative energy can be directly used as acceleration energy for another axis. And because there is no heat generated by regeneration resistance, designing control panels to shed heat is easy.

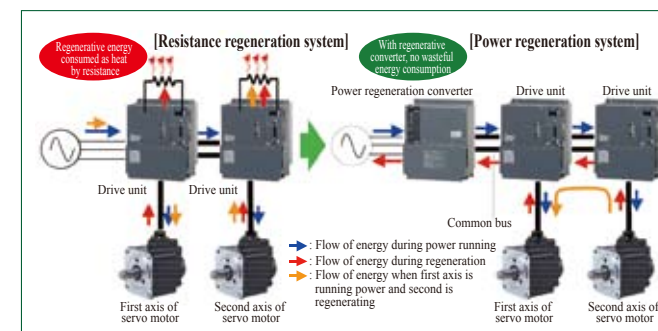

You save energy because the power regeneration converter returns regenerative energy of deceleration to the power source.

By connecting two or more axes with a common bus, regenerative energy can be directly used as acceleration energy for another axis.

Because there is no heat generated by regeneration resistance, designing control panels to shed heat is easy. You can also use less main circuit power cable.

The selection and adjustment of motors is the same as with the MR-J3 Series.

MR-J3-DU Series energy conservation effectiveness (with 10 kW of regenerative power)

- [Resistance regeneration system]
 - Consumption during resistance
 - 10 kW approximately equals 10 kW of regenerative power
 - [Power regeneration system]
 - Since power regeneration converter efficiency is about 90% or more,
 - About 9 kW of power returns to the power source
- Assuming 5,000 hours of operation/year at an electricity cost of 17yen/kWh, **the savings would be 765,000yen/year**

Eco-Friendly and Energy-Conservative Servo Amplifier for a More Compact Machine at a Smaller Cost.

■ MR-J3W-B Series : Two-Axis Servo Amplifier

Announcing the MR-J3W-B Series SSCNET III compatible two-axis AC servo amplifier. One unit of this servo amplifier operates any combination of two rotary or linear servo motors and has the high performance, functionality and usability of the J3 Series B Type. You can reduce the equipment footprint by about 17% - 25% as compared to installing two units of the MR-J3, making your system more compact and reducing its wiring needs.

SSCNET III compatible two-axis servo amplifier

One unit of this servo amplifier operates any combination of two rotary or linear servo motors or direct drive motors (direct drive motor compatibility coming soon) and has the high performance, functionality and usability of the MR-J3-B servo amplifier.

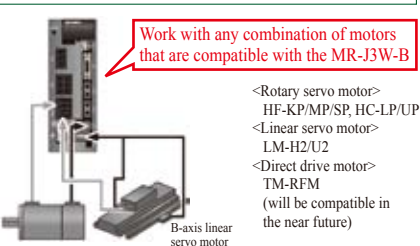

Space-saving and reduced wiring

- Two servo motors are operated with just one servo amplifier, reducing the servo amplifier footprint.
- The two axes use the same main circuit and control circuit power supply and SSCNET III cables, greatly reducing wiring.
- Using the product in combination with the Q170MCPUCPU stand alone motion controller allows the overall system, including controller, to be made even more compact.
- Using a linear servo motor for the driver also enables a more compact mechanical component.

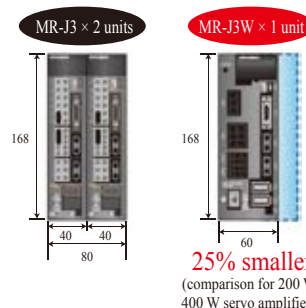

Contributes to energy savings

Two motors are operated by a common power supply, ensuring effective use of the regenerative energy.

<Operation pattern>

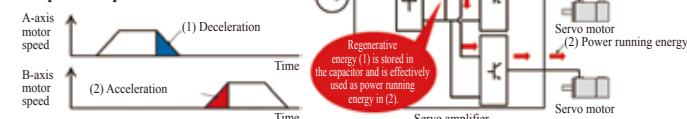

Eco-Conscious Spindle Motor for Energy Savings, Higher Durability and Shorter Machining Times.

■ SJ-D Series : CNC Spindle Motor

With the increasing demand for environmental protection, the SJ-D Series of CNC spindle motors was born to provide high performance with a focus on energy and resource savings as well as safety and reliability. Aiming at a design that enhances product reliability, our new motors feature a blend of design and functionality. This product won the Good Design Award for 2009.



High efficiency (energy savings)

The optimized electrical design lowers the motor energy loss by approximately 25% as compared to our conventional model and reduces power consumption. The lower electricity cost and reduced thermal displacement ensure higher machine accuracy.

High speed

The maximum rotation speed is increased by incorporating a high-speed specification bearing as standard. This offers a wider variety of machining conditions and enables process consolidation, resulting in shorter machining times.

Lightweight / low vibration

To enhance machine accuracy, rigidity was increased by reducing the body mass, and motor vibration was reduced (to V3 in the case of the SJ-D Series (normal specifications)). This motor enables higher machining accuracy.

Enhanced reliability

Component degradation is suppressed and service life is prolonged by using a new grease-filled bearing and reducing the motor's temperature rise thanks to lower energy loss.

M70 Series, MDS-D-V2-S808

Motor energy loss comparison

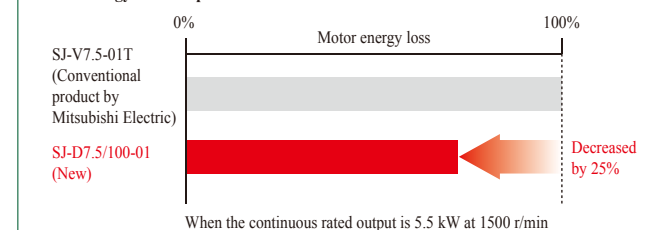

Diverse solutions that promote energy efficiency in factories.

Visualize the energy consumption of each piece of equipment and control energy usage on the shop floor. We offer solutions that realize factory-wide optimization through effective utilization of energy information.

By introducing Mitsubishi Electric's FA energy solution "e&eco-F@ctory," you can
 [1] Detect unnecessary production processes, [2] Detect inconsistencies in product quality,
 [3] Ensure preventive maintenance of production equipment, and [4] Analyse manufacturing costs in detail.
 By doing so, you can then manage the production efficiency (specific energy consumption) of each product and equipment. As a result, good balance can be achieved between improving productivity and energy efficiency and reducing manufacturing and energy costs, and a Just-In-Time approach to energy (supplying energy only when, where and quantity needed) can be realized.



ENERGY MONITORING SYSTEM

By monitoring the energy usage and specific energy consumption of each equipment and instrument in real time, unexpected problems be discovered, energy consumption can be reduced, and energy loss can be minimized.

- (1) Waste: idle operations, pre-production time loss, equipment standby time, surplus equipment
- (2) Variation: Extraction rate, production efficiency
- (3) Quality control: identification of good/non-good products, equipment lifecycle management
- (4) Alarm: monitoring of equipment trouble, issuance of warnings and malfunction alerts

ENERGY CONTROL SYSTEM

Energy use is controlled in accordance with each production process, to conserve energy and increase energy efficiency in each equipment and instrument.

- (1) Implementation of scheduled operations that automatically power control each equipment and instrument in accordance with production plans
- (2) Optimum control of each equipment and instrument in accordance with production performance and operating conditions
- (3) Control of machining speed based on the inventory of works in progress

Manage Energy Usage

Solutions That Make Energy Use Visible Are Powerful Tools for Your Energy Management Program.

Real time monitoring of your equipment's total and specific energy consumption is critical to linking production information and energy information and making improvements.

This lets you discover problems, find where to make improvements, focus on reducing consumption and decide what improvements to make.

The e&eco-F@ctory system uses dependable solutions from our partners to smooth out and continuously improve the PDCA cycle of energy efficiency.

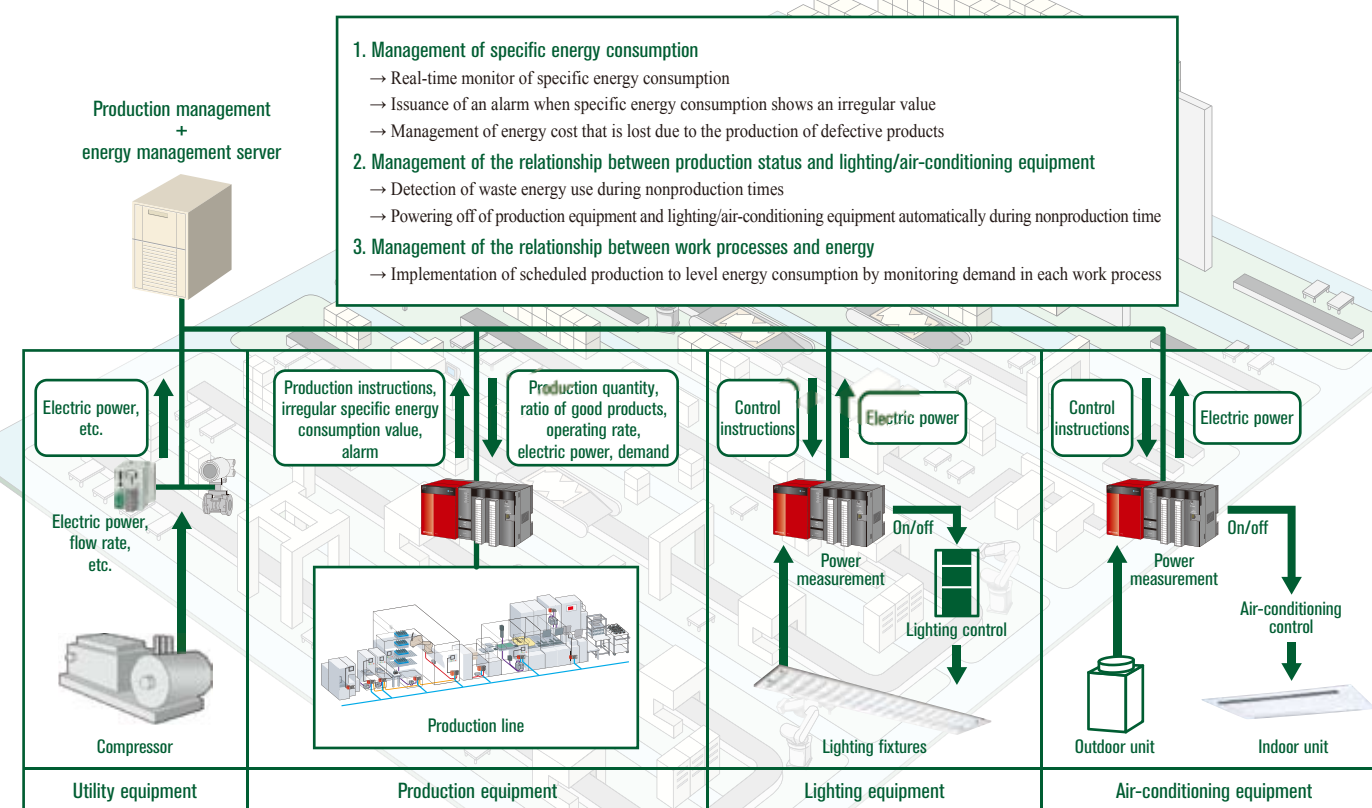
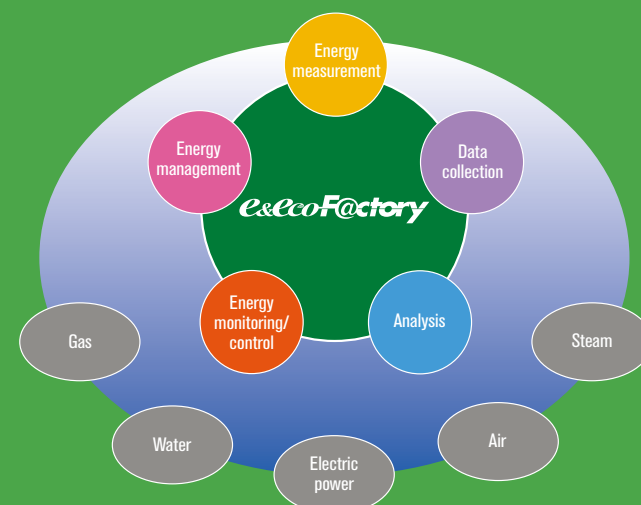

NAGOYA WORKS

An e&eco-F@ctory is in operation at Nagoya Works to specifically verify the efficiency and effectiveness of the innovative solution.

Mitsubishi Electric's Nagoya Works (Nagoya City, Aichi Prefecture) was among the first to incorporate the e&eco-F@ctory concept in order to "visualize" energy consumption per production equipment. In addition to EcoServer II and EcoMonitorPro, Nagoya Works also introduced a MELSEC-Q Series power measuring unit, so that by combining production information collected by the e-F@ctory system and energy information, it can discover wasteful production processes based on energy usage and achieve greater productivity.

Example of quality control on the assembly line: Servo motor factory (commenced operations in May 2005)



Quality improvement is achieved through real-time quality control.

The figure below shows one of the newest examples of an e&eco-F@ctory, which pursues operational management, real-time quality control, quality management, and energy management under the main themes of "detailed and real-time" information. MES Interface Modules form the core of the e&eco-F@ctory to effectively link control system devices directly to the enterprise system.

- Quality information
- Operation information
- Instructional information
- Electric power information
- PLCs equipped with an MES Interface Module

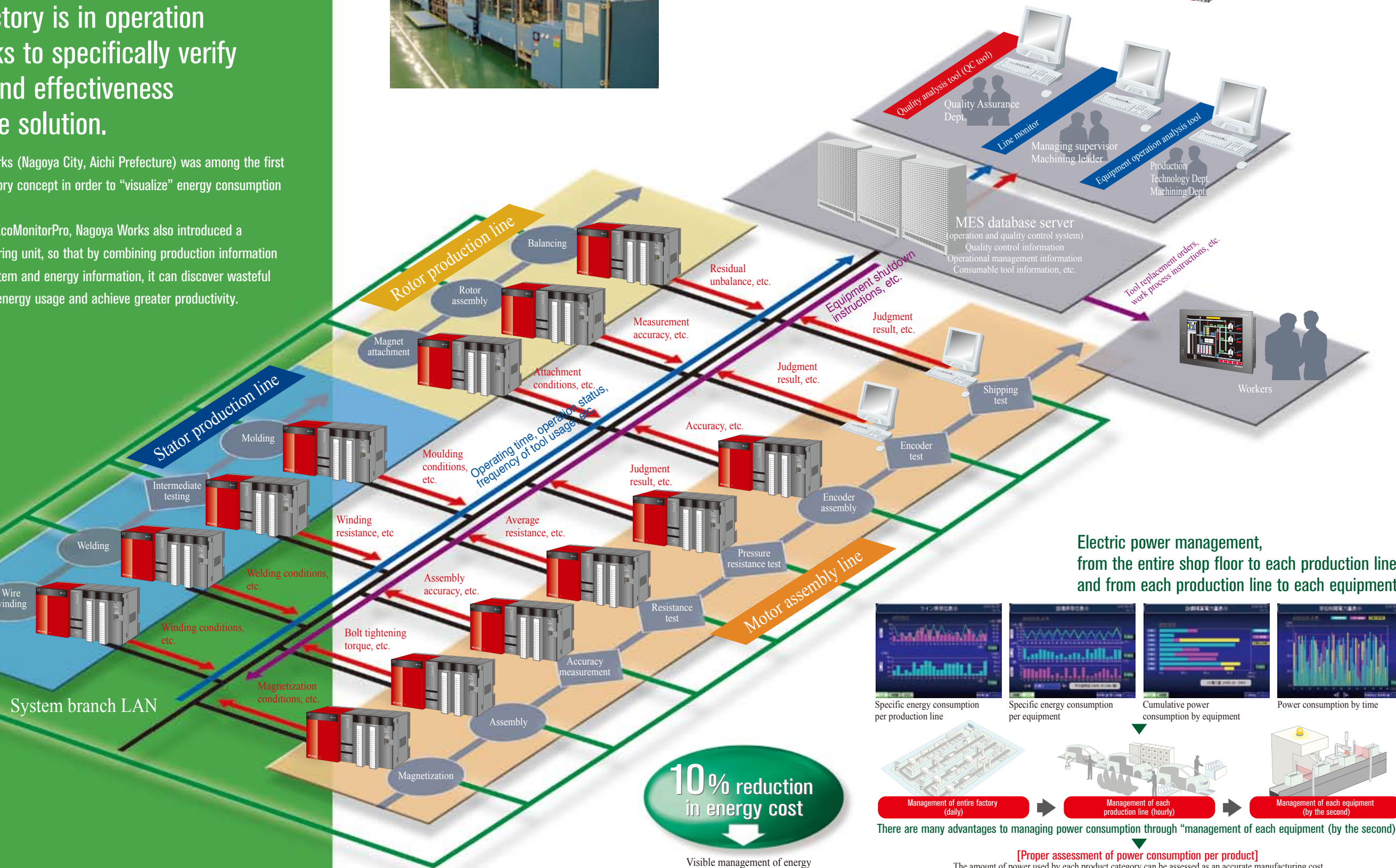

Electric power management, from the entire shop floor to each production line, and from each production line to each equipment.

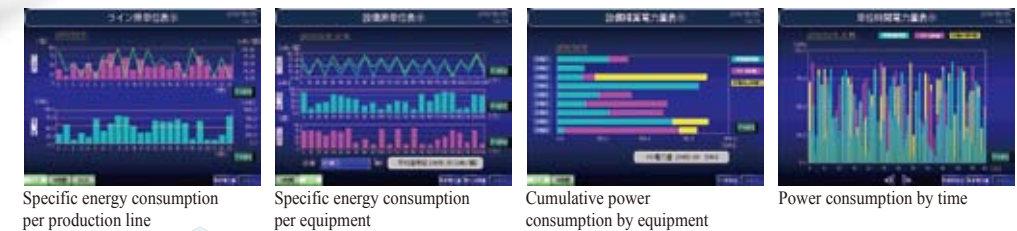

10% reduction in energy cost

Visible management of energy by department and detailed management of specific energy consumption

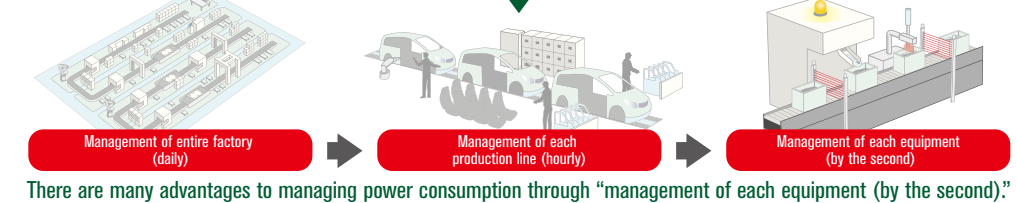

There are many advantages to managing power consumption through "management of each equipment (by the second)."

[Proper assessment of power consumption per product]
The amount of power used by each product category can be assessed as an accurate manufacturing cost. The amount of power that is wasted by the occurrence of rejects can be assessed.

[Proper assessment of power consumption per equipment status]
The amount of power that is wasted during standby mode and malfunctions can be assessed.

FUKUYAMA WORKS

Fukuyama Works makes aggressive energy conservation efforts through "visible management."

Mitsubishi Electric's Fukuyama Works (Fukuyama City, Hiroshima Prefecture) adopted "visible management" in 1997, and now practices aggressive energy conservation efforts. It has realized an economical and ecological eco-factory, and uses its eco expertise to engage in the energy conservation business.

Under its policy of "visible energy conservation," it visualizes all aspects of energy usage in the factory as it implements factory-wide energy conservation activities.

The knowledge it gains through these activities is incorporated in the development of energy-saving products.

27.3% reduction in specific energy consumption
*2006 performance compared to 1990

Reduction of approx. **23 million yen** in basic power cost
*2006 performance compared to 1990

Reduction of approx. **100 million yen** in total power cost
*2006 performance compared to 1990

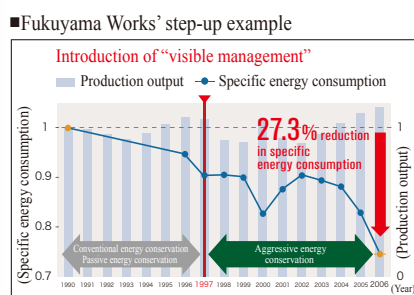

System for management of specific energy consumption in each work process System improvement

Support for reducing specific electric energy consumption

- System improvements are made by measuring the power usage and production output of each work process and managing specific energy consumption based on those measurements.
- "Visible management" is realized by using Intranet Web-based PCs.

Screen example

Web-based energy conservation support system Management and monitoring systems

Visible support of energy conservation activities

The EcoServerII Web-based data server makes accumulated data available on the Web via the Intranet in an easy understanding manner, to promote greater energy conservation efforts.

Visualization of energy usage

Data posted on an EMS Website accessible from a client PC

Web-based data server

Electric energy management system Management and monitoring systems

Total support of energy and labor saving efforts in the factory

Electricity, gas, temperature, and other energy-related data in the factory is recorded and monitored in detail through a B/NET network of power distribution and control equipment.

LAN (Ethernet)

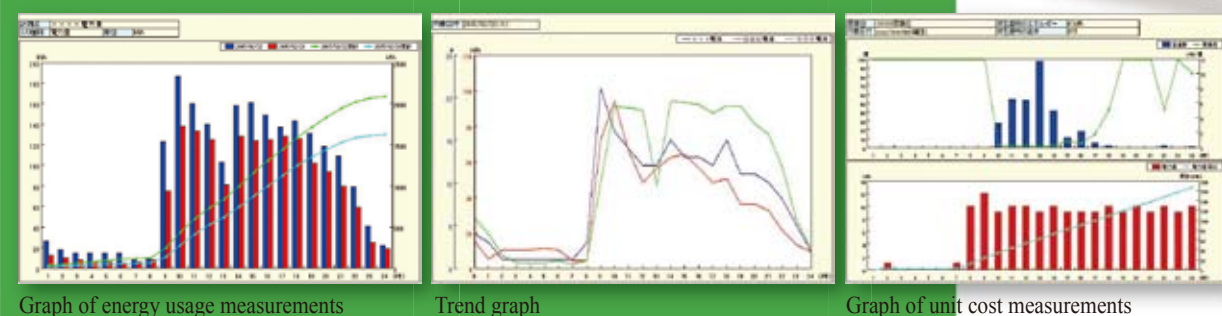
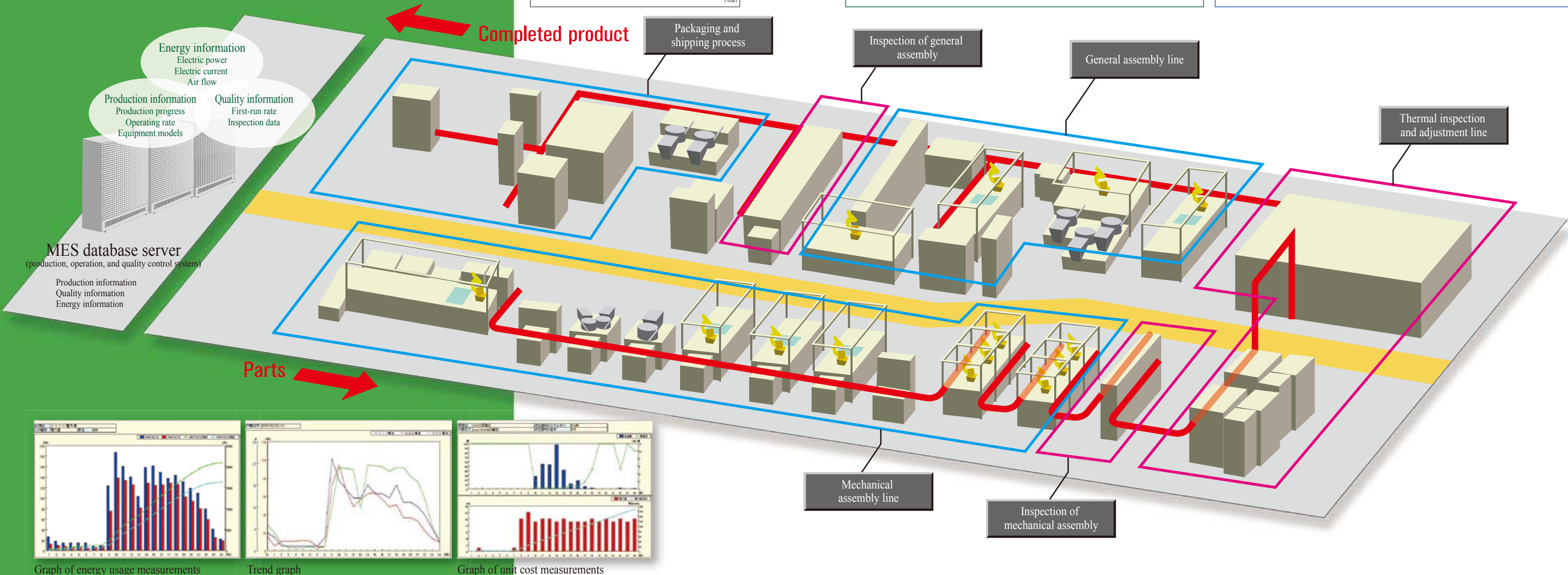

Precautions for Choosing the Products

This catalog explains the typical features and functions of the GOT1000 series HMI and does not provide restrictions and other information on usage and module combinations.

When using the products, always read the user's manuals of the products.

Mitsubishi will not be held liable for damage caused by factors found not to be the cause of Mitsubishi; machine damage or lost profits caused by faults in the Mitsubishi products; damage, secondary damage, accident compensation caused by special factors unpredictable by Mitsubishi; damages to products other than Mitsubishi products; and to other duties.

For safe use

- To use the products given in this catalog properly, always read the related manuals before starting to use them.
- The products within this catalog have been manufactured as general-purpose parts for general industries and have not been designed or manufactured to be incorporated into any devices or systems used in purpose related to human life.
- Before using any product for special purposes such as nuclear power, electric power, aerospace, medicine or passenger movement vehicles, consult with Mitsubishi.
- The products within this catalog have been manufactured under strict quality control. However, when installing the product where major accidents or losses could occur if the product fails, install appropriate backup or failsafe functions in the system.

Country/Region	Sales office	Tel/Fax
USA	Mitsubishi Electric Automation Inc. 500 Corporate Woods Parkway, Vernon Hills, IL 60061, USA	Tel: +1-847-478-2100 Fax: +1-847-478-0327
Brazil	MELCO-TEC Rep. Com.e Assessoria Tecnica Ltda. Av. Paulista, 1439-CJ. 72 Cerqueira Cesar CEP 01311-200, Sao Paulo, SP, CEP: 01311-200, Brazil	Tel: +55-11-3146-2200 Fax: +55-11-3146-2217
Germany	Mitsubishi Electric Europe B.V. German Branch Gothaer Strasse 8, D-40880 Ratingen, Germany	Tel: +49-2102-486-0 Fax: +49-2102-486-1120
UK	Mitsubishi Electric Europe B.V. UK Branch Travellers Lane, Hatfield, Hertfordshire, AL10 8XB, UK.	Tel: +44-1707-276100 Fax: +44-1707-278992
Italy	Mitsubishi Electric Europe B.V. Italy Branch Viale Colleoni 7-20041 Agrate Brianza (Milano), Italy	Tel: +39-039-60531 Fax: +39-039-6053312
Spain	Mitsubishi Electric Europe B.V. Spanish Branch Ctra. de Rubí 76-80-AC.420, E-08190 Sant Cugat del Vallés (Barcelona), Spain	Tel: +34-93-565-3131 Fax: +34-93-589-1579
France	Mitsubishi Electric Europe B.V. French Branch 25, Boulevard des Bouvets, F-92741 Nanterre Cedex, France	Tel: +33-1-5568-5568 Fax: +33-1-5568-5757
Czech Republic	Mitsubishi Electric Europe B.V. Czech Branch Avenir Business Park, Radlická 714/113a CZ-158 00 Praha 5	Tel: +420-251-551-470 Fax: +420-251-551-471
Poland	Mitsubishi Electric Europe B.V. Polish Branch ul. Krakowska 50 32-083 Balice, Poland	Tel: +48-12-630-47-00 Fax: +48-12-630-47-01
Russia	Mitsubishi Electric Europe B.V. Moscow Office 52/3, Kosmodamianskaya nab., 115054, Moscow, Russia	Tel: +7-812-633-3497 Fax: +7-812-633-3499
South Africa	Circuit Breaker Industries Ltd. Private Bag 2016, ZA-1600 Isando, South Africa	Tel: +27-11-928-2000 Fax: +27-11-392-2354
China	Mitsubishi Electric Automation (China) Ltd. 17/F, ChuangXing Financial Center No.288 West Nanjing Road, Shanghai 200003	Tel: +86-21-2322-3030 Fax: +86-21-2322-3000
Taiwan	Setsuyo Enterprise Co., Ltd. 6F, No.105 Wu-Kung 3rd Rd, Wu-Ku Hsiang, Taipei Hsien 248, Taiwan	Tel: +886-2-2299-2499 Fax: +886-2-2299-2509
Korea	Mitsubishi Electric Automation Korea Co., Ltd. 1480-6, Gayang-dong, Gangseo-ku, Seoul 157-200, Korea	Tel: +82-2-3660-9552 Fax: +82-2-3664-8372
Singapore	Mitsubishi Electric Asia Pte, Ltd. 307 Alexandra Road #05-01/02, Mitsubishi Electric Building Singapore 159943	Tel: +65-6470-2460 Fax: +65-6476-7439
Thailand	Mitsubishi Electric Automation (Thailand) Co., Ltd. Bang-Chan Industrial Estate No.111 Soi Serithai 54, T.Kannayao, A.Kannayao, Bangkok 10230 Thailand	Tel: +66-2-517-1326 Fax: +66-2-517-1328
Indonesia	P.T. Autoteknindo Sumber Makmur Muara Karang Selatan, Block A / Utara No.1 Kav. No.11, Kawasan Industri Pergudangan, Jakarta- Utara 14440, P.O.Box 5045 Jakarta11050-Indonesia	Tel: +62-21-663-0833 Fax: +62-21-663-0832
India	Mitsubishi Electric India Pvt. Ltd 2nd Floor, DLF Building No.9B, DLF Cyber City, DLF Phase III, Gurgaon-122 009	Tel: +91-124-463-0300 Fax: +91-124-463-0399
Australia	Mitsubishi Electric Australia Pty. Ltd. 348 Victoria Road, Rydalmere, N.S.W. 2116, Australia	Tel: +61-2-9684-7777 Fax: +61-2-9684-7245



HEAD OFFICE: TOKYO BUILDING, 2-7-3, MARUNOUCHI, CHIYODA-KU, TOKYO 100-8310, JAPAN
NAGOYA WORKS: 1-14, YADA-MINAMI 5, HIGASHI-KU, NAGOYA, JAPAN

When exported from Japan, this manual does not require application to the Ministry of International Trade and Industry for service transaction permission.