

*Changes for the Better*

General-Purpose AC Servo MELSERVO-J4 Series

Functional Safety Unit MR-D30

Servo Motors with Functional Safety HG-KR\_W0C/HG-SR\_W0C/HG-JR\_W0C

January 2015

**New Product Release**

SV1404-2E-A

# Increasing the Safety Level with the MR-D30 Functional Safety Unit

 Servo amplifier  
MR-J4-10B-RJ

 Functional safety unit  
MR-D30

Safety is the top priority in today's automation industry. Mitsubishi's new servo motors with functional safety support safety observation functions (STO/SS1/SS2/SOS/SBC/SLS/SSM) which are compliant with Category 4 PL e, SIL 3.

MR-D30 is now compatible with both MR-J4-B-RJ and MR-J4-A-RJ, allowing to configure your system more flexible.

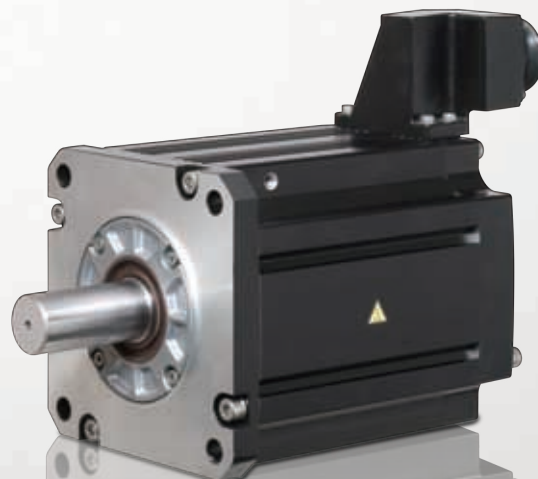
 Servo motor with functional safety  
HG-JR703W0C

## Functional safety unit MR-D30

- In addition to MR-J4-B-RJ, MR-D30 functional safety unit is now compatible with MR-J4-A-RJ. **NEW**
- SOS and SS2 are achievable in addition to STO, SS1, SBC, SLS, and SSM. **NEW**
- A combination with Motion controller (Q17nDSCPU) enables safety communication through SSCNET III/H and reduced wirings.

## Servo motors with functional safety HG-KR\_W0C/HG-SR\_W0C/HG-JR\_W0C **NEW**

- With the servo motors with functional safety, safety observation functions of SS2, SOS, SLS, and SSM compliant to Category 4 PL e, SIL 3 are achievable.

# Achieving Category 4 PL e, SIL 3 with MR-D30



## Compatible with Category 4 PL e, SIL 3 Drive Safety

By wiring safety input signals to MR-D30 functional safety unit, safety observation function of Category 4 PL e, SIL 3 is achieved. The safety observation function of MR-D30 is compatible with status monitor (safety output) function, in addition to the functions in the table defined as "Function of power drive system" by IEC/EN 61800-5-2.



MR-D30 has obtained the functional safety approval of TÜV SÜD.

### ■ Safety observation function achieved by MR-D30

IEC/EN 61800-5-2:2007 function
STO (Safe torque off)
SS1 (Safe stop 1)
SS2 (Safe stop 2)
SOS (Safe operating stop)
SLS (Safely-limited speed)
SBC (Safe brake control)
SSM (Safe speed monitor)

The following safety levels are achievable. Note that achievable safety level depends on whether the safety observation function is achieved through SSCNET III/H or by connecting the safety input/output directly to the functional safety unit, and whether the servo motors with functional safety are used or not.

	Direct wiring to functional safety unit	Reduced wiring through SSCNET III/H
Servo motor with functional safety	Category 4 PL e, SIL 3 (STO/SS1/SS2/SOS/SLS/SBC/SSM)	Category 3 PL d, SIL 2 (STO/SS1/SS2/SOS/SLS/SBC/SSM)*1
Servo motor	Category 4 PL e, SIL 3 (STO/SS1/SBC) Category 3 PL d, SIL 2 (SLS/SSM)	Category 3 PL d, SIL 2 (STO/SS1/SLS/SBC/SSM)

\*1. The servo motor with functional safety will be compatible with the reduced wiring system through SSCNET III/H in the near future.

## Compatible with Pulse Train Command

NEW

MR-D30 functional safety unit is compatible with MR-J4-A-RJ servo amplifier with general-purpose interface. The safety observation function with MR-D30 can be used with position control by pulse train command and speed control by analog voltage command.

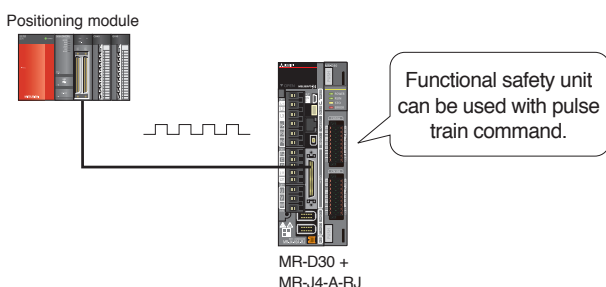

## Servo Motors with Functional Safety

NEW

Owing to the encoder with improved safety, a combination of the servo motor with functional safety and MR-D30 functional safety unit supports STO/SS1/SS2/SOS/SLS/SBC/SSM which are compliant with Category 4 PL e, SIL 3.

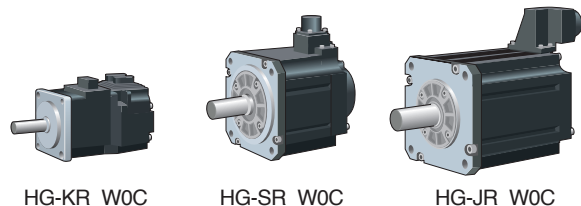

The safety level will be increased by inputting signals directly to the functional safety unit, and the wiring will be reduced by inputting the safety signals through SSCNET III/H.

### Compatible with Category 4 PL e, SIL 3 By Wiring to Functional Safety Unit

Category 4 PL e, SIL 3 is achieved by inputting safety signals directly to MR-D30 functional safety unit. Because the safety observation function is operated on MR-D30 side, expansion of the safety observation function is possible without depending on controllers, offering a selection from a wide variety of controllers such as Simple Motion modules, Motion controllers, and Positioning modules. Moreover, the safety observation function is easily enabled just by setting parameters.

IEC/EN 61800-5-2:2007 function	Safety level
STO (Safe torque off)	Category 4 PL e, SIL 3
SS1 (Safe stop 1)	
SS2 (Safe stop 2)*1	
SOS (Safe operating stop)*1	
SLS (Safely-limited speed)*2	
SBC (Safe brake control)	
SSM (Safe speed monitor)*2	

\*1. SS2 and SOS are achievable by using the servo motor with functional safety unit.  
 \*2. The safety level would be Category 3 PL d, SIL 2 when the servo motor with functional safety is not used.

For general-purpose pulse train command (MR-J4-A-RJ + MR-D30) **NEW**

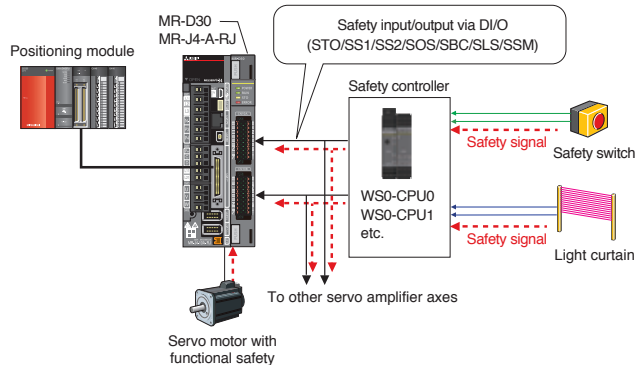

For SSCNETIII/H command (MR-J4-B-RJ + MR-D30)

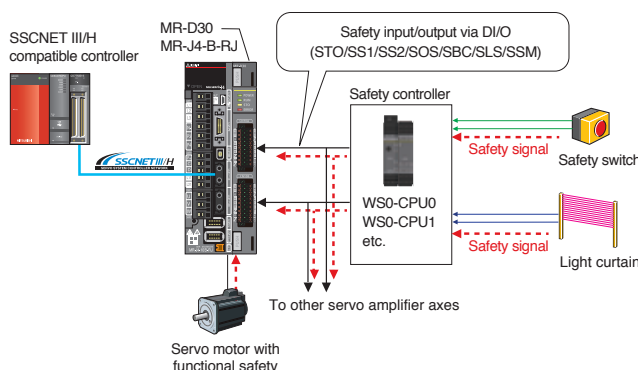

### Reduced Wiring though SSCNET III/H

When MR-J4-B-RJ servo amplifier is combined with MR-D30 functional safety unit, safety signals are inputted from Q17nDSCPU Motion controller\*1 through SSCNET III/H. Thus, the STO cables between the controller and the servo amplifiers for sending the power shut-off signals are not necessary anymore, greatly reducing wiring time and cost. Moreover, because the servo motor with functional safety support SS2 and SOS, no additional external encoders will be necessary to achieve SS2 and SOS in the near future\*3. As the safety observation function is achieved on the MR-D30 side, cost of designing ladder program on the controller side can be reduced as well.

IEC/EN 61800-5-2:2007 function	Safety level
STO (Safe torque off)	Category 3 PL d, SIL 2
SS1 (Safe stop 1)	
SS2 (Safe stop 2)*2	
SOS (Safe operating stop)*2	
SLS (Safely-limited speed)	
SBC (Safe brake control)	
SSM (Safe speed monitor)	

\*1. The safety observation function has obtained the approval of Certification Body by the combination of Q17nDSCPU, Q173DSXY and QnUD(E)(H)CPU.  
 \*2. SS2 and SOS will be achievable in the near future by using the servo motors with functional safety unit.  
 \*3. The servo motor with functional safety will be compatible with the reduced wiring system through SSCNET III/H in the near future.

Safety observation function with a combination of Motion controller and servo amplifier

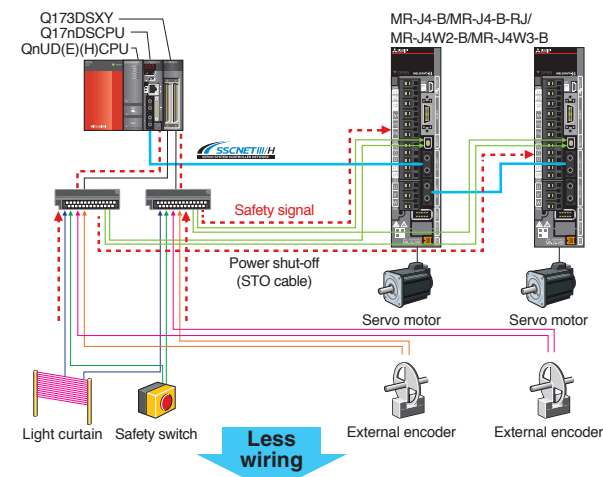

Reduced wiring with a combination of functional safety unit and Motion controller

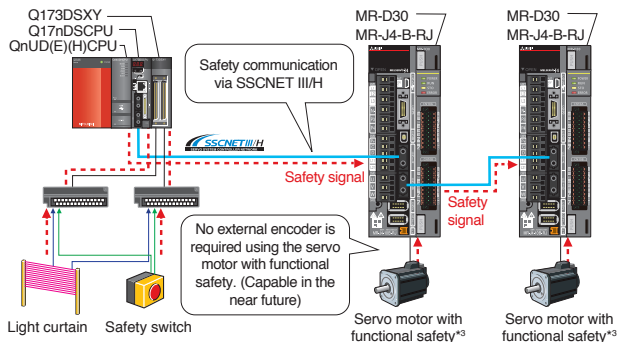

## Easy Setting by MR Configurator2

Safety observation function can be easily set with parameters on MR Configurator2\*1.

The visual display offers intuitive parameter setting.

Example of SS1 (Safe stop 1) setting window



\*1. Be sure to update your MR Configurator2 to the latest version.

## Safety System As Necessary

Expanding the safety observation function only for the necessary axes is possible by combining the servo amplifier and MR-D30 functional safety unit, enabling to configure safety system that perfectly suits your application.

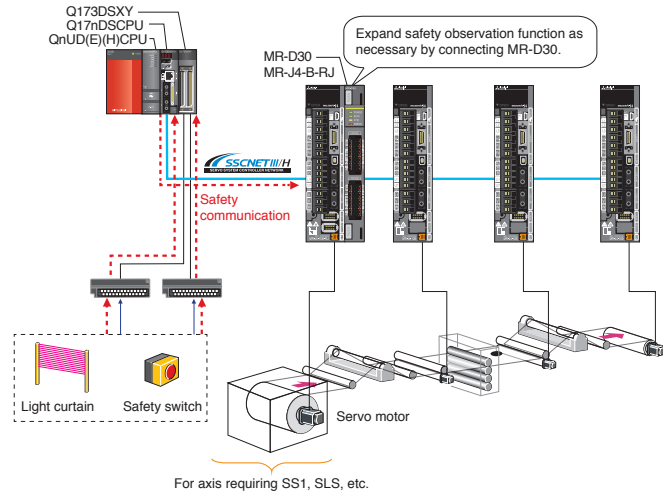

## Example of Machine Application

### Automated machineries

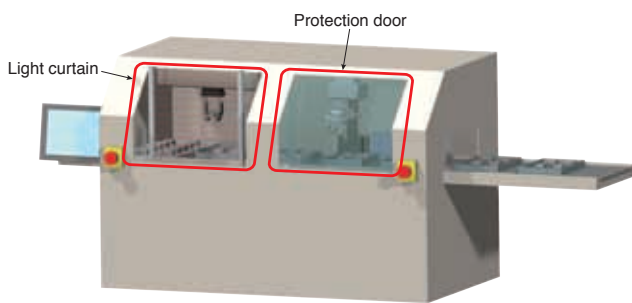

Use SLS and SSM to the axes in a carrying area to operate a machine within a safety speed limit. This enables safe maintenance and setting-up without stopping the machine and improves operational efficiency.

### Press machines

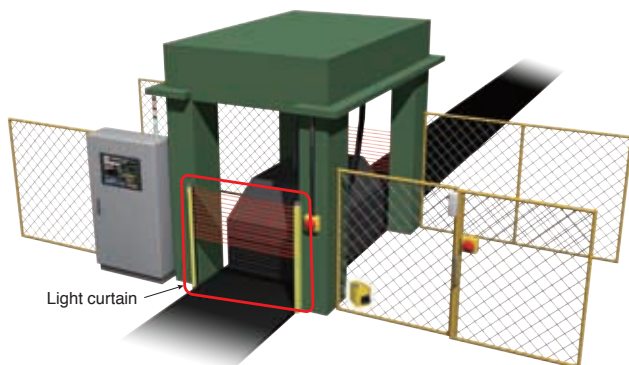

Use STO and SBC to the axes in a presswork area of a machine. This allows to shut down the power supplying to a pressing part during replacement of a mold without shutting down the machine.

### Machining lines

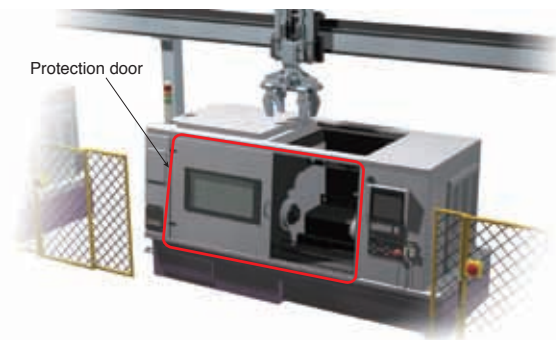

Use SOS to the axes in a working chamber to stop the moving parts of a machine. This allows an operator to remove a workpiece without shutting down the machine.

### Printing machines

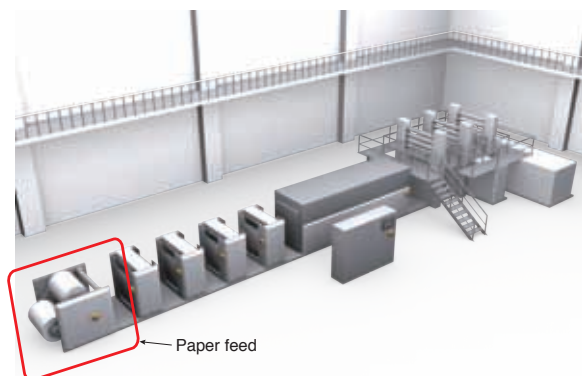

Use STO to a paper-feeding axis and SLS to a driving part in a printing machine. STO shuts down the power to the paper-feeding axis without removing the power to the whole printing system. SLS operates the machine within a safe speed limit, allowing an operator to do maintenance and inspection without shutting down the power to the driving part.



MR-D30 functional safety unit is equipped with safety observation function (STO/SS1/SS2/SOS/SLS/SBC/SSM) compliant with "EN ISO 13849-1 Category 4 PL e and Category 3 PL d". All the safety of human lives and properties are not guaranteed by these functions. Execute risk assessment by user and reduce the level of risk until the residual risk is less than the tolerable risk.

## IEC/EN 61800-5-2 Function

The safety observation function of MR-D30 is defined as "Function of power drive system" by IEC/EN 61800-5-2 and compatible to the functions. Motions of safety observation function are as follows.

IEC61800-5-2 Safety standard	
<p><b>Safe torque off (STO)</b></p> <p>The STO function shuts off power to the motor electronically using the internal circuit by responding to the input signal from external equipment (shuts off through secondary-side output). This function corresponds to the Stop category 0 of IEC/EN 60204-1. Execute the STO function after the motor is stopped in servo off state.</p>	
<p><b>Safe stop 1 (SS1)</b></p> <p>Responding to the input signal from external equipment, the motor starts to decelerate. After the set delay time for motor stop is passed, the STO function starts. This function corresponds to the Stop category 1 of IEC 60204-1.</p>	
<p><b>Safe stop 2 (SS2)</b></p> <p>Responding to the input signal from external equipment, the motor starts to decelerate. After the set delay time for motor stop is passed, the SOS function starts. This function corresponds to the Stop category 2 of IEC/EN 60204-1.</p>	
<p><b>Safe operating stop (SOS)</b></p> <p>This function monitors the position of the motor not to deviate from the specified range. Power is still supplied to the motor during the SOS function.</p>	
<p><b>IEC61800-5-2 Safety standard</b></p> <p><b>Safely-limited speed (SLS)</b></p> <p>This function monitors the motor not to exceed the required speed limit. If the speed exceeds the limit, the motor power is shut off by the STO.</p>	
<p><b>Safe brake control (SBC)</b></p> <p>The SBC signals are outputted for external brake control.</p>	
<p><b>Safe speed monitor (SSM)</b></p> <p>The SSM signals are outputted when the motor speed is below the specified speed limit.</p>	

V: Speed  
Vmax: User specified speed limit value  
S1, S2: Specified stop position  
■ Ensured safety range

## Related Catalogs



MELSERVO-J4 Catalog  
L(NA)03058



Mitsubishi Servo System  
Controllers Catalog  
L(NA)03062



Safety Programmable Controller/  
Safety Controller/Safety Relay Module  
MELSEC Safety Catalog  
L(NA)080192E



Mitsubishi Safety Solutions Catalog  
L(NA)08142E

## MR-J4-B-RJ and MR-D30 Connections with Peripheral Equipment (Note 1, 3)

Peripheral equipment is connected to MR-J4-B-RJ and MR-D30 as described below. Connectors, cables, options, and other necessary equipment are available so that users can set up the servo amplifier easily and start using it right away.

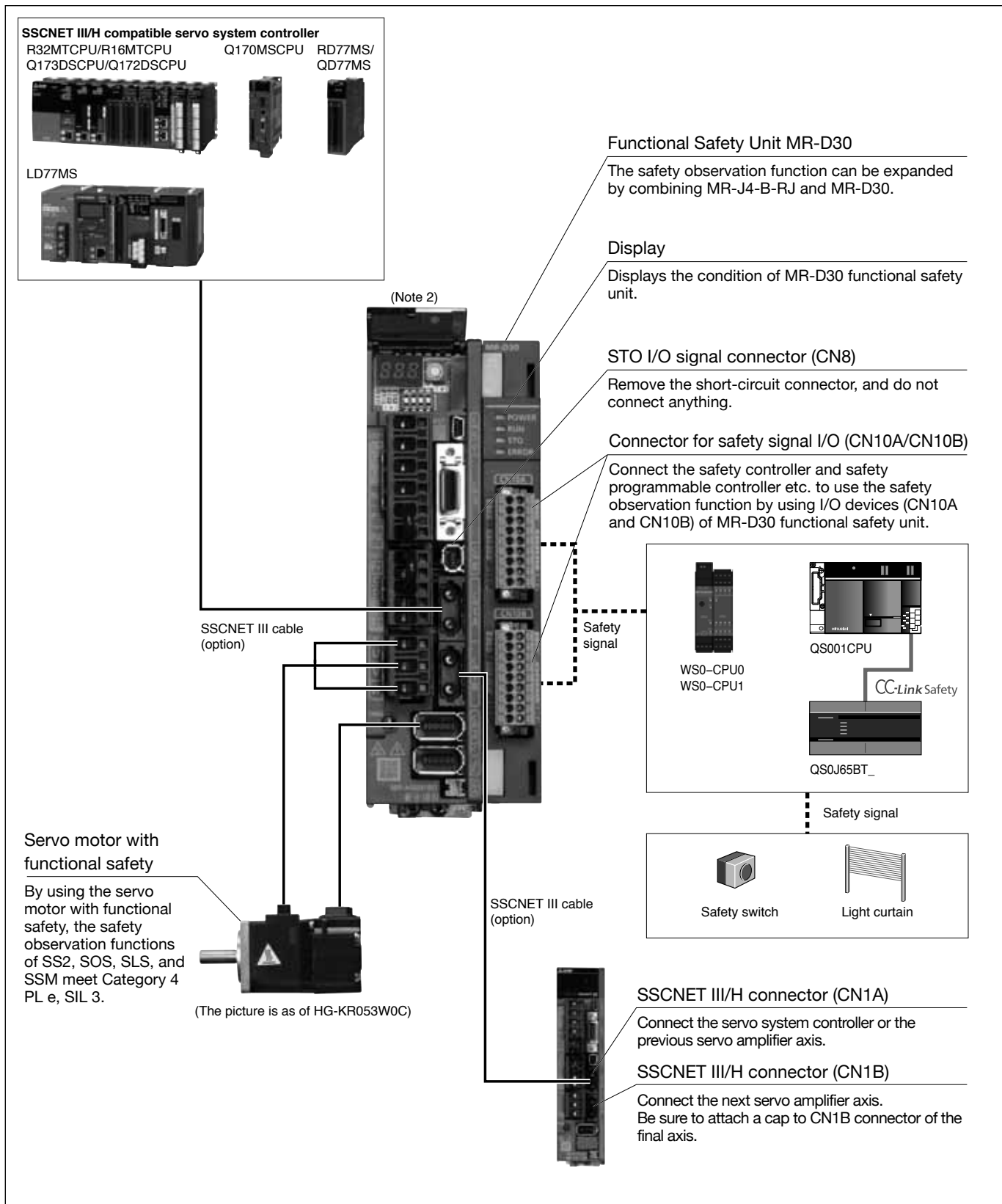

Notes: 1. The connection with the peripheral equipment is an example for MR-J4-350B-RJ or smaller servo amplifiers. Refer to "MR-J4-\_-(-RJ) Servo Amplifier Instruction Manual" and "MR-D30 Instruction Manual" for the actual connections.

2. This picture shows when the display cover is open.

3. The wirings are the same as MR-J4-\_-(-RJ) servo amplifier except for the mentioned wiring. Refer to "MELSERVO-J4 catalog L(NA)03058".

## MR-J4-A-RJ and MR-D30 Connections with Peripheral Equipment (Note 1, 3)

Peripheral equipment is connected to MR-J4-A-RJ and MR-D30 as described below. Connectors, cables, options, and other necessary equipment are available so that users can set up the servo amplifier easily and start using it right away.

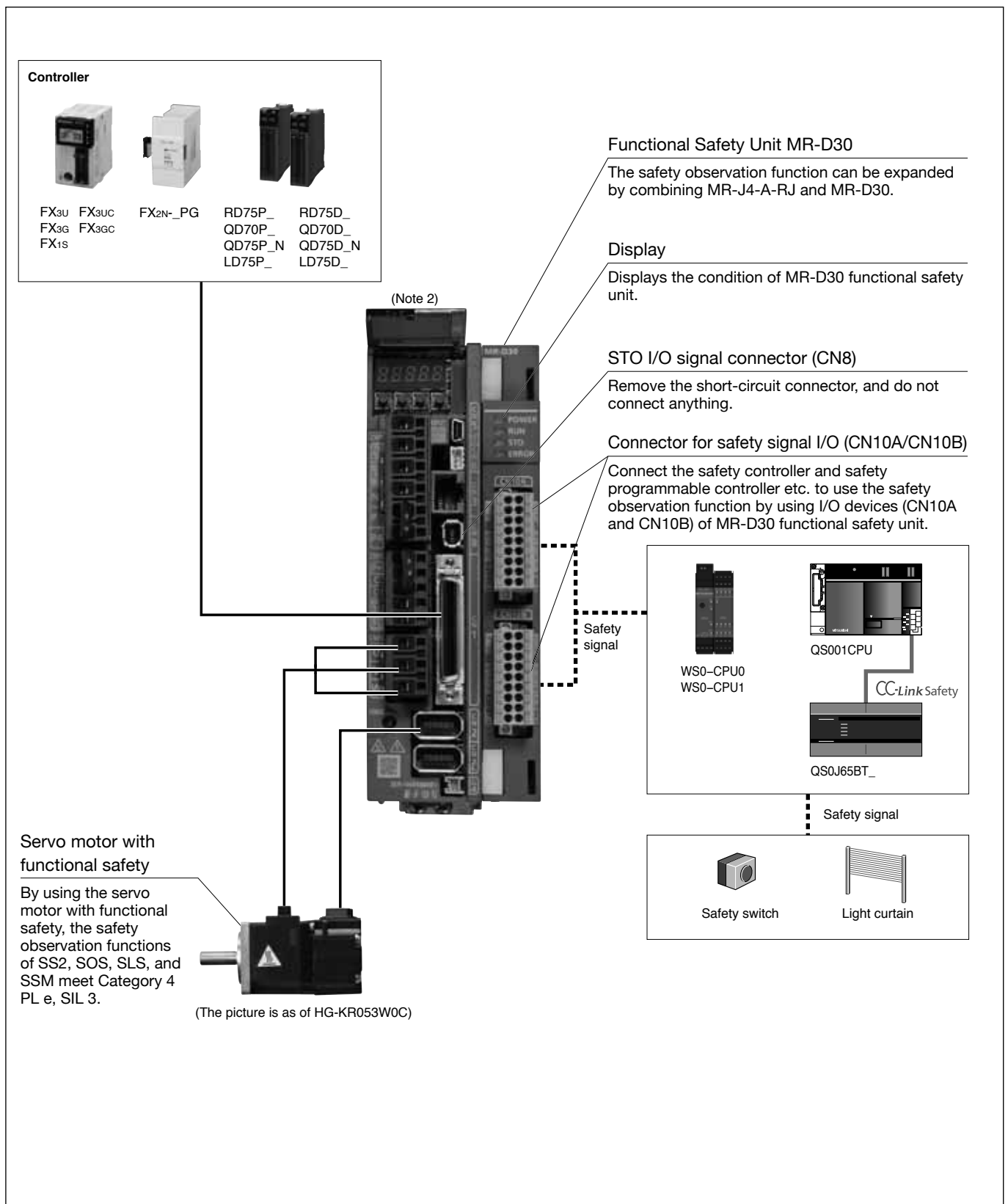

Notes: 1. The connection with the peripheral equipment is an example for MR-J4-350A-RJ or smaller servo amplifiers. Refer to "MR-J4-\_A\_(-RJ) Servo Amplifier Instruction Manual" and "MR-D30 Instruction Manual" for the actual connections.  
 2. This picture shows when the display cover is open.  
 3. The wirings are the same as MR-J4-\_A\_(-RJ) servo amplifier except for the mentioned wiring. Refer to "MELSERVO-J4 catalog L(NA)03058".

## Model Designation for Functional Safety Unit

**MR-D30**

Functional safety unit

### List of compatible software version

Achievable safety observation function depends on the software versions of MR-D30 and the servo amplifier, and compatibility of the servo motor with functional safety. Refer to the table below:

MR-D30 software version	Servo amplifier software version	Safety observation function (IEC/EN 61800-5-2)	Servo motors with functional safety	Servo amplifier
A0	B3/B4	STO/SS1/SBC/SLS/SSM	Not usable	MR-J4- _B_-RJ
	B5 or later	STO/SS1/SBC/SLS/SSM	Not usable	MR-J4- _B_-RJ
A1	B3/B4	STO/SS1/SBC/SLS/SSM	Not usable	MR-J4- _B_-RJ
	B5 or later	STO/SS1/SBC/SLS/SSM/SOS/SS2	Usable	MR-J4- _B_-RJ MR-J4- _A_-RJ <sup>(Note 1)</sup>

Notes: 1. MR-J4- \_A\_-RJ manufactured in November 2014 or later is compatible with MR-D30.

## Model Designation for Servo Amplifier

**MR-J4-10B-RJ**

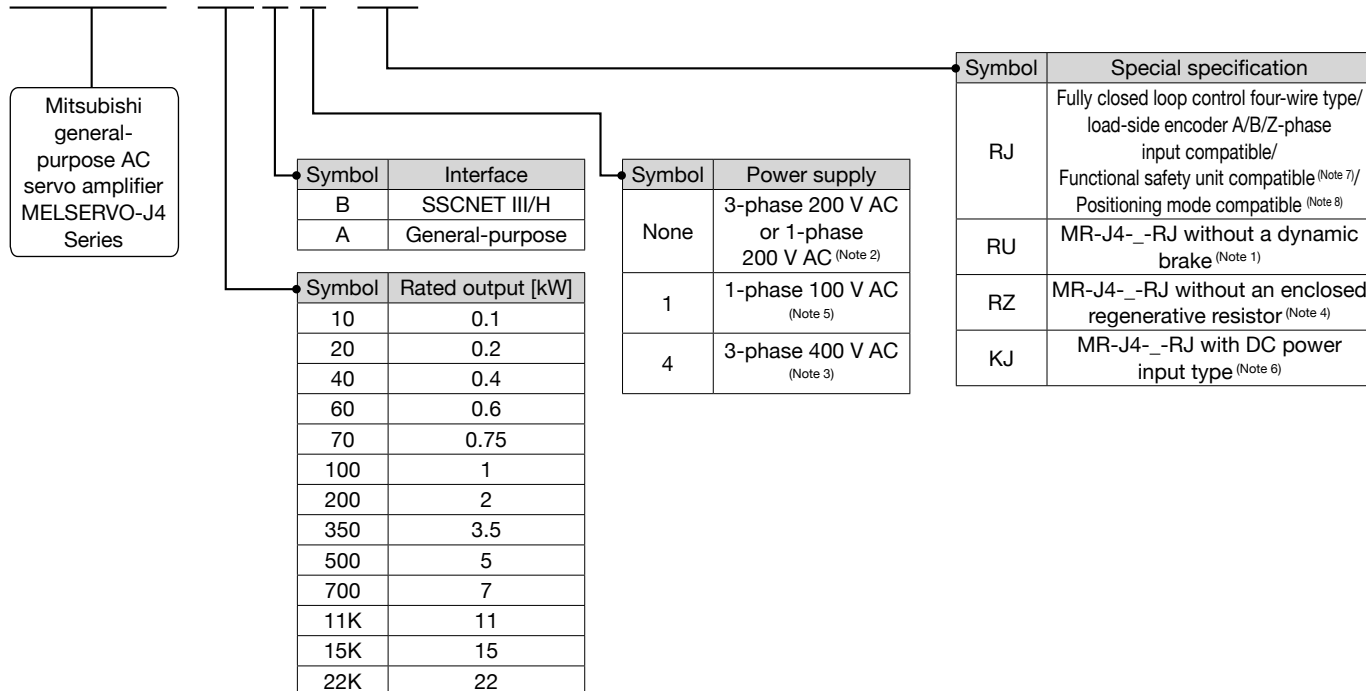

Notes: 1. Dynamic brake which is built in 7 kW or smaller servo amplifiers is removed. When using the servo amplifier without a dynamic brake, the servo motor does not stop immediately at alarm occurrence or power failure. Take measures to ensure safety on the entire system.

When the following servo motors are used, an electronic dynamic brake may operate at alarm occurrence.

HG-KR053, HG-KR13, HG-KR23, HG-KR43, HG-MR053, HG-MR13, HG-MR23, HG-MR43, HG-SR51, and HG-SR52

Disable the electronic dynamic brake by setting the following parameter to " \_ \_ \_ 2."

For MR-J4-B-RJ: [Pr. PF06]

For MR-J4-A-RJ: [Pr. PF09]

In addition, when [Pr. PA04] is set to "2 \_ \_ \_" (initial value), the servo motor may be decelerated to a stop forcibly at alarm occurrence. The forced stop deceleration function will be disabled by setting [Pr. PA04] to "0 \_ \_ \_"

2. Servo amplifiers of 0.75 kW or smaller are available for 1-phase 200 V AC.

3. Servo amplifiers of 0.6 kW, and 1 kW or larger are available for 3-phase 400 V AC.

4. Available in 11 kW to 22 kW servo amplifier. A regenerative resistor (standard accessory) is not enclosed.

5. Servo amplifiers of 0.4 kW or smaller are available.

6. Contact your local sales office for the DC power input type servo amplifier.

7. When using MR-D30, use MR-J4-B-RJ servo amplifier with software version B3 or later, or MR-J4-A-RJ servo amplifier with software version B5 or later.

8. The positioning mode is available with MR-J4-A-RJ servo amplifiers. Use MR-J4-A-RJ servo amplifiers with software version B3 or later.



NEW

## Model Designation for Servo Motors with Functional Safety

HG - KR 05 3 B W0C

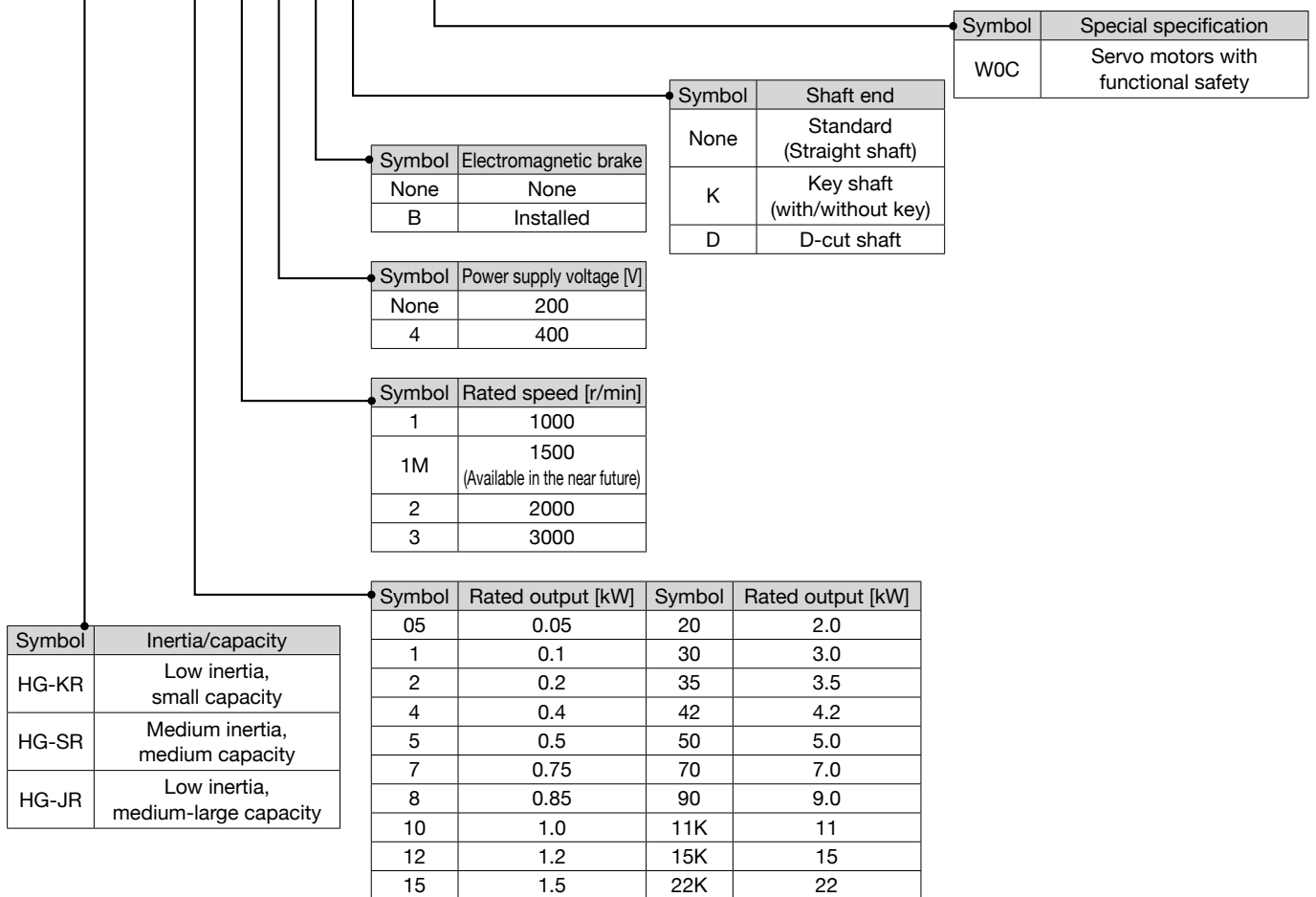

● Specifications and dimensions for servo motors with functional safety are the same as those for HG-KR\_(B), HG-SR\_(B), and HG-JR\_(B). Refer to "MELSERVO-J4 catalog L(NA)03058".  
● MR-BT6VCASE battery case cannot be used in a system using the servo motors with functional safety.

### Model Designation for Rotary Servo Motor Model Designation for Linear Servo Motor Model Designation for Direct Drive Motor

Refer to "MELSERVO-J4 catalog L(NA)03058" for the model designation of rotary servo motor, linear servo motor, and direct drive motor.

## Combinations of Compatible Servo Amplifier and Servo Motor (200 V)

Servo amplifier	Rotary servo motor	Servo motor with functional safety	Linear servo motor (primary side) <sup>(Note 1)</sup>	Direct drive motor
MR-J4-10B-RJ MR-J4-10A-RJ	HG-KR053, 13 HG-MR053, 13	HG-KR053W0C, 13W0C	-	-
MR-J4-20B-RJ MR-J4-20A-RJ	HG-KR23 HG-MR23	HG-KR23W0C	LM-U2PAB-05M-0SS0 LM-U2PBB-07M-1SS0	TM-RFM002C20
MR-J4-40B-RJ MR-J4-40A-RJ	HG-KR43 HG-MR43	HG-KR43W0C	LM-H3P2A-07P-BSS0 LM-H3P3A-12P-CSS0 LM-K2P1A-01M-2SS1 LM-U2PAD-10M-0SS0 LM-U2PAF-15M-0SS0	TM-RFM004C20
MR-J4-60B-RJ MR-J4-60A-RJ	HG-SR51, 52 HG-JR53	HG-SR51W0C, 52W0C HG-JR53W0C	LM-U2PBD-15M-1SS0	TM-RFM006C20 TM-RFM006E20
MR-J4-70B-RJ MR-J4-70A-RJ	HG-KR73 HG-MR73 HG-JR73 HG-UR72	HG-KR73W0C HG-JR73W0C	LM-H3P3B-24P-CSS0 LM-H3P3C-36P-CSS0 LM-H3P7A-24P-ASS0 LM-K2P2A-02M-1SS1 LM-U2PBF-22M-1SS0	TM-RFM012E20 TM-RFM012G20 TM-RFM040J10
MR-J4-100B-RJ MR-J4-100A-RJ	HG-SR81, 102 HG-JR53 <sup>(Note 2)</sup> , 103	HG-SR81W0C, 102W0C HG-JR53W0C <sup>(Note 2)</sup> , 103W0C	-	TM-RFM018E20
MR-J4-200B-RJ MR-J4-200A-RJ	HG-SR121, 201, 152, 202 HG-JR73 <sup>(Note 2)</sup> , 103 <sup>(Note 2)</sup> , 153, 203 HG-RR103, 153 HG-UR152	HG-SR121W0C, 201W0C, 152W0C, 202W0C HG-JR73W0C <sup>(Note 2)</sup> , 103W0C <sup>(Note 2)</sup> , 153W0C, 203W0C	LM-H3P3D-48P-CSS0 LM-H3P7B-48P-ASS0 LM-H3P7C-72P-ASS0 LM-FP2B-06M-1SS0 LM-K2P1C-03M-2SS1 LM-U2P2B-40M-2SS0	-
MR-J4-350B-RJ MR-J4-350A-RJ	HG-SR301, 352 HG-JR153 <sup>(Note 2)</sup> , 203 <sup>(Note 2)</sup> , 353 HG-RR203 HG-UR202	HG-SR301W0C, 352W0C HG-JR153W0C <sup>(Note 2)</sup> , 203W0C <sup>(Note 2)</sup> , 353W0C	LM-H3P7D-96P-ASS0 LM-K2P2C-07M-1SS1 LM-K2P3C-14M-1SS1 LM-U2P2C-60M-2SS0	TM-RFM048G20 TM-RFM072G20 TM-RFM120J10
MR-J4-500B-RJ MR-J4-500A-RJ	HG-SR421, 502 HG-JR353 <sup>(Note 2)</sup> , 503 HG-RR353, 503 HG-UR352, 502	HG-SR421W0C, 502W0C HG-JR353W0C <sup>(Note 2)</sup> , 503W0C	LM-FP2D-12M-1SS0 LM-FP4B-12M-1SS0 LM-K2P2E-12M-1SS1 LM-K2P3E-24M-1SS1 LM-U2P2D-80M-2SS0	TM-RFM240J10
MR-J4-700B-RJ MR-J4-700A-RJ	HG-SR702 HG-JR503 <sup>(Note 2)</sup> , 703, 601, 701M	HG-SR702W0C HG-JR503W0C <sup>(Note 2)</sup> , 703W0C, 701MW0C <sup>(Note 3)</sup>	LM-FP2F-18M-1SS0 LM-FP4D-24M-1SS0	-
MR-J4-11KB-RJ MR-J4-11KA-RJ	HG-JR903, 801, 12K1, 11K1M	HG-JR903W0C, 11K1MW0C <sup>(Note 3)</sup>	LM-FP4F-36M-1SS0	-
MR-J4-15KB-RJ MR-J4-15KA-RJ	HG-JR15K1, 15K1M	HG-JR15K1MW0C <sup>(Note 3)</sup>	LM-FP4H-48M-1SS0	-
MR-J4-22KB-RJ MR-J4-22KA-RJ	HG-JR20K1, 25K1, 22K1M	HG-JR22K1MW0C <sup>(Note 3)</sup>	-	-

Notes: 1. Models of the linear servo motor primary side are listed in this page. For compatible models of the secondary side, refer to "Combination of Linear Servo Motor and Servo Amplifier" in "MELSERVO-J4 Catalog L(NA)03058".

2. The maximum torque can be increased from 300% to 400% of the rated torque with this combination.

3. Available in the near future.

### Combinations of Compatible Servo Amplifier and Servo Motor (100 V)

Servo amplifier	Rotary servo motor	Servo motor with functional safety	Linear servo motor (primary side) <sup>(Note 1)</sup>	Direct drive motor
MR-J4-10B1-RJ MR-J4-10A1-RJ	HG-KR053, 13 HG-MR053, 13	HG-KR053W0C, 13W0C	-	-
MR-J4-20B1-RJ MR-J4-20A1-RJ	HG-KR23 HG-MR23	HG-KR23W0C	LM-U2PAB-05M-0SS0 LM-U2PBB-07M-1SS0	TM-RFM002C20
MR-J4-40B1-RJ MR-J4-40A1-RJ	HG-KR43 HG-MR43	HG-KR43W0C	LM-H3P2A-07P-BSS0 LM-H3P3A-12P-CSS0 LM-K2P1A-01M-2SS1 LM-U2PAD-10M-0SS0 LM-U2PAF-15M-0SS0	TM-RFM004C20

### Combinations of Compatible Servo Amplifier and Servo Motor (400V)

Servo amplifier	Rotary servo motor	Servo motor with functional safety	Linear servo motor (primary side) <sup>(Note 1)</sup>	Direct drive motor
MR-J4-60B4-RJ MR-J4-60A4-RJ	HG-SR524 HG-JR534	HG-SR524W0C HG-JR534W0C	-	-
MR-J4-100B4-RJ MR-J4-100A4-RJ	HG-SR1024 HG-JR534 <sup>(Note 2)</sup> , 734, 1034	HG-SR1024W0C HG-JR534W0C <sup>(Note 2)</sup> , 734W0C, 1034W0C	-	-
MR-J4-200B4-RJ MR-J4-200A4-RJ	HG-SR1524, 2024 HG-JR734 <sup>(Note 2)</sup> , 1034 <sup>(Note 2)</sup> , 1534, 2034	HG-SR1524W0C, 2024W0C HG-JR734W0C <sup>(Note 2)</sup> , 1034W0C <sup>(Note 2)</sup> , 1534W0C, 2034W0C	-	-
MR-J4-350B4-RJ MR-J4-350A4-RJ	HG-SR3524 HG-JR1534 <sup>(Note 2)</sup> , 2034 <sup>(Note 2)</sup> , 3534	HG-SR3524W0C HG-JR1534W0C <sup>(Note 2)</sup> , 2034W0C <sup>(Note 2)</sup> , 3534W0C	-	-
MR-J4-500B4-RJ MR-J4-500A4-RJ	HG-SR5024 HG-JR3534 <sup>(Note 2)</sup> , 5034	HG-SR5024W0C HG-JR3534W0C <sup>(Note 2)</sup> , 5034W0C	-	-
MR-J4-700B4-RJ MR-J4-700A4-RJ	HG-SR7024 HG-JR5034 <sup>(Note 2)</sup> , 7034, 6014, 701M4	HG-SR7024W0C HG-JR5034W0C <sup>(Note 2)</sup> , 7034W0C, 701M4W0C <sup>(Note 3)</sup>	-	-
MR-J4-11KB4-RJ MR-J4-11KA4-RJ	HG-JR9034, 8014, 12K14, 11K1M4	HG-JR9034W0C, 11K1M4W0C <sup>(Note 3)</sup>	-	-
MR-J4-15KB4-RJ MR-J4-15KA4-RJ	HG-JR15K14, 15K1M4	HG-JR15K1M4W0C <sup>(Note 3)</sup>	-	-
MR-J4-22KB4-RJ MR-J4-22KA4-RJ	HG-JR20K14, 25K14, 22K1M4	HG-JR22K1M4W0C <sup>(Note 3)</sup>	LM-FP5H-60M-1SS0	-

Notes: 1. Models of the linear servo motor primary side are listed in this page. For compatible models of the secondary side, refer to "Combination of Linear Servo Motor and Servo Amplifier" in "MELSERVO-J4 Catalog L(NA)03058".

2. The maximum torque can be increased from 300% to 400% of the rated torque with this combination.

3. Available in the near future.

## System Configuration Examples

For using I/O device of functional safety unit <sup>(Note 2)</sup>

The following is a system configuration example to use the safety observation function by using input/output devices (CN10A and CN10B) of MR-D30 functional safety unit.

### ● MR-J4-B-RJ

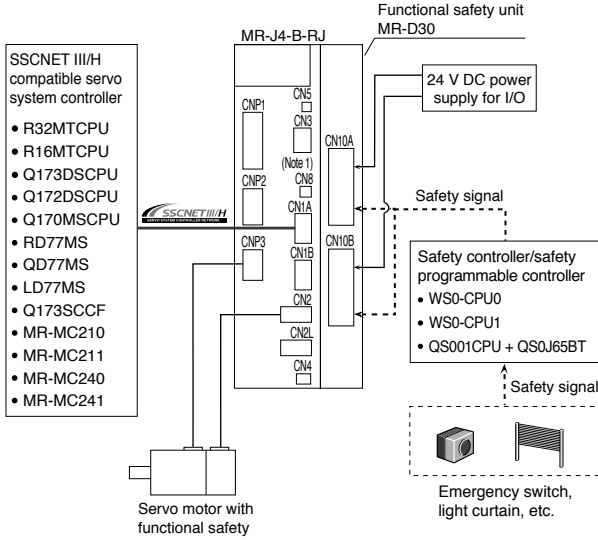

### ● MR-J4-A-RJ

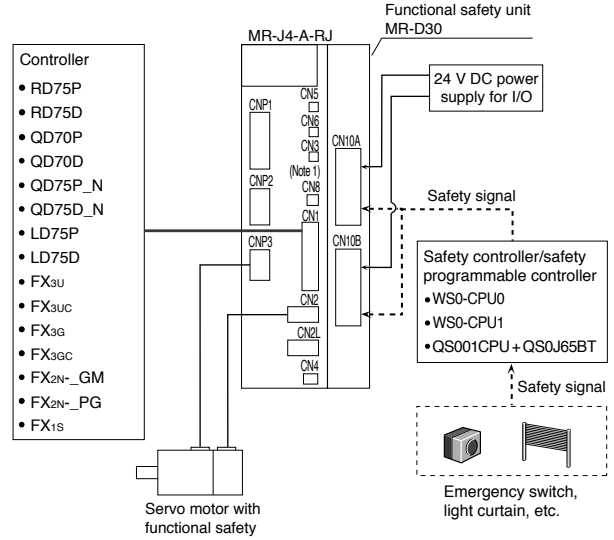

For using input signal of SSCNET III/H compatible Motion controller <sup>(Note 2)</sup>

The following is a system configuration example to use the safety observation function from SSCNET III/H compatible Motion controller through SSCNET III/H.

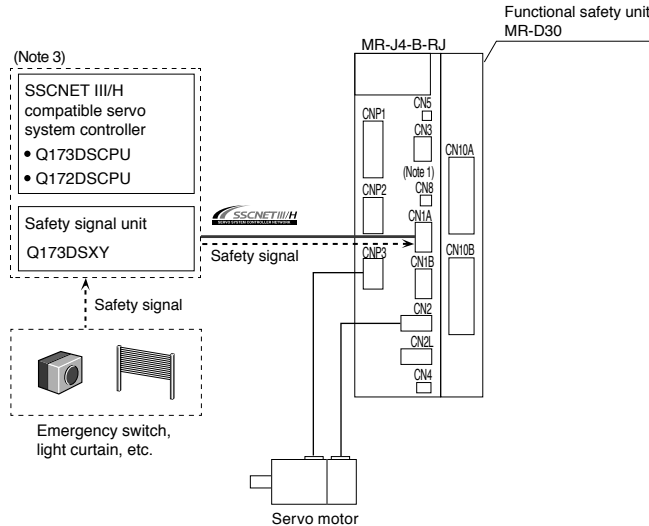

Notes: 1. Disconnect the short-circuit connector applied to CN8 connector of the servo amplifier, and do not connect anything when using MR-D30.

2. The wirings are the same as MR-J4-B-RJ/MR-J4-A-RJ servo amplifier except for the mentioned wiring.

3. The safety observation function has obtained the approval of Certification Body only by the combination of Q17nDSCPU, Q173DSXY and QnUD(E)(H)CPU.

## Specifications

Model		MR-D30
Output	Rated voltage	24 V DC
	Rated current [A]	0.3
Interface power supply	Voltage	24 V DC $\pm$ 10%
	Power supply capacity [A]	0.8 <sup>(Note 1)</sup>
Safety performance	Standards certified by CB	EN ISO 13849-1 Category 4 PL e and Category 3 PL d IEC 61508 SIL 2 and SIL 3 EN 62061 SIL CL 2 and SIL CL 3 EN 61800-5-2 SIL 2 and SIL 3
	Mean time to dangerous failure	MTTFd $\geq$ 100 [year]
	Effectiveness of safety observation system or safety observation subsystem	DC = 90 [%]
	Probability of dangerous Failure per Hour	PFH = $6.57 \times 10^{-9}$ [1/h]
	Mission time	TM = 20 [year]
	Response performance <sup>(Note 2)</sup>	Using input device: 15 ms or less
	Speed observation resolution	Depends on a command resolution (0.1 r/min or less at 22-bit position command)
	Position observation resolution	1/32 rev
	Input device	6 points $\times$ 2 systems (source/sink)
	Output device	Source: 3 points $\times$ 2 systems and 1 point $\times$ 1 system Sink: 1 point $\times$ 1 system
Safety observation function (IEC/EN 61800-5-2)	Safe torque off (STO)	Category 4 PL e, SIL 3 <sup>(Note 3)</sup> /Category 3 PL d, SIL 2
	Safe stop 1 (SS1)	Category 4 PL e, SIL 3 <sup>(Note 3)</sup> /Category 3 PL d, SIL 2
	Safe stop 2 (SS2) <sup>(Note 5, 6)</sup>	Category 4 PL e, SIL 3 <sup>(Note 3)</sup> /Category 3 PL d, SIL 2
	Safe operating stop (SOS) <sup>(Note 5, 6)</sup>	Category 4 PL e, SIL 3 <sup>(Note 3)</sup> /Category 3 PL d, SIL 2
	Safely-limited speed (SLS) <sup>(Note 5)</sup>	Category 4 PL e, SIL 3 <sup>(Note 3, 4)</sup> /Category 3 PL d, SIL 2
	Safe brake control (SBC)	Category 4 PL e, SIL 3 <sup>(Note 3)</sup> /Category 3 PL d, SIL 2
	Safe speed monitor (SSM) <sup>(Note 5)</sup>	Category 4 PL e, SIL 3 <sup>(Note 3, 4)</sup> /Category 3 PL d, SIL 2
Safety observation function	Status monitor (STO/SOS)	Category 4 PL e, SIL 3/Category 3 PL d, SIL 2 <sup>(Note 7)</sup>
Compliance to global standards	CE marking	EMC: EN 61800-3 MD: EN ISO 13849-1, EN 61800-5-2, EN 62061
Structure (IP rating)		Natural cooling, open (IP20 when mounted on servo amplifier and IP00 for MR-D30 alone)
Environment	Ambient temperature	Operation: 0 °C to 55 °C (non-freezing), storage: -20 °C to 65 °C (non-freezing)
	Ambient humidity	Operation/Storage: 5 %RH to 90 %RH (non-condensing)
	Ambience	Indoors (no direct sunlight); no corrosive gas, inflammable gas, oil mist or dust
	Altitude	1000 m or less above sea level
	Vibration resistance	5.9 m/s <sup>2</sup> at 10 Hz to 57 Hz
Mass	[kg]	0.15

- Notes: 1. This is the value applicable when all I/O signals are used. The current capacity can be decreased by reducing the number of I/O points.  
2. Time from STO input to energy shut off.  
3. To meet Category 4 PL e, SIL 3, an input diagnosis using test pulse is required.  
4. To meet Category 4 PL e, SIL 3, a combination with HG-KR\_W0C, HG-SR\_W0C, or HG-JR\_W0C servo motor is required.  
5. Linear servo system, direct drive servo system, and fully closed loop system are not compatible with SLS, SS2, and SOS.  
6. To achieve SS2 and SOS, a combination with HG-KR\_W0C, HG-SR\_W0C, or HG-JR\_W0C servo motor is required.  
7. Refer to "MR-D30 Instruction Manual" for achievable safety level.

# Connection Example

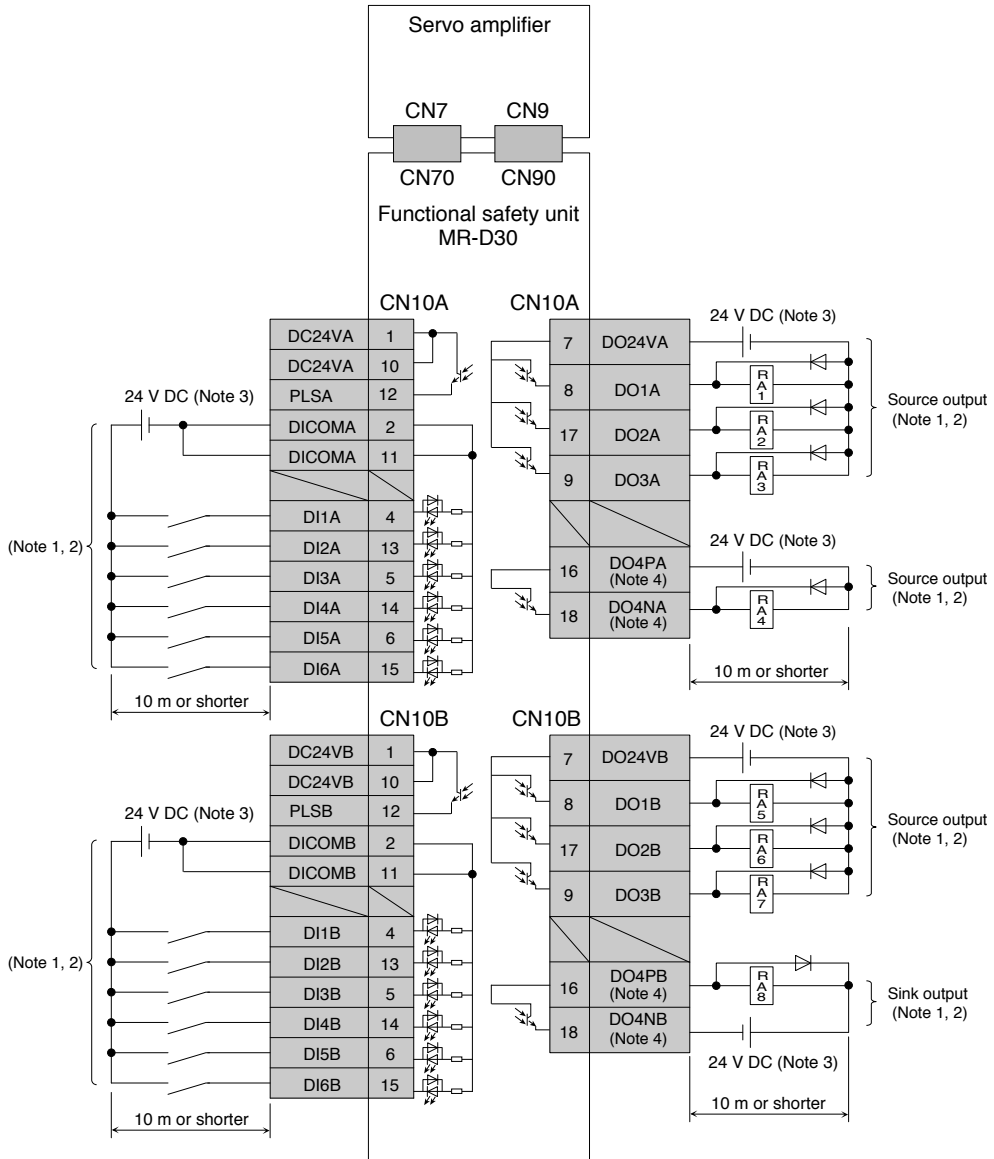

Notes: 1. Separate all of the external wirings into two systems. Connect separately even for the input and output power supply (24 V DC and 0 V common) connection. Do not wire between CN10A and CN10B.

2. Assign each I/O device by the combination of connector pins shown in the table below. Refer to "MR-D30 Instruction Manual" for each device.

Combination for input connector pin
DI1A (CN10A-4)/DI1B (CN10B-4)
DI2A (CN10A-13)/DI2B (CN10B-13)
DI3A (CN10A-5)/DI3B (CN10B-5)
DI4A (CN10A-14)/DI4B (CN10B-14)
DI5A (CN10A-6)/DI5B (CN10B-6)
DI6A (CN10A-15)/DI6B (CN10B-15)

Combination for output connector pin
DO1A (CN10A-8)/DO1B (CN10B-8)
DO2A (CN10A-17)/DO2B (CN10B-17)
DO3A (CN10A-9)/DO3B (CN10B-9)
DO4NA (CN10A-18)/DO4PB (CN10B-16)

3. Provide an external power supply of 24 V DC  $\pm$  10% for the interface. When all input/output points are used, the total current capacity of 0.8 A is required. The current capacity can be decreased by reducing the number of I/O points. For convenience of illustration, the diagram shows separate 24 V DC power supplies for input and output signals. However, the input and output signals can share a common power supply.
4. DO4PA (CN10A-16), DO4NA (CN10A-18), DO4PB (CN10B-16) and DO4NB (CN10B-18) are not available with MR-D30 manufactured in September 2014 or earlier. Do not connect anything to these pins.

## Dimensions

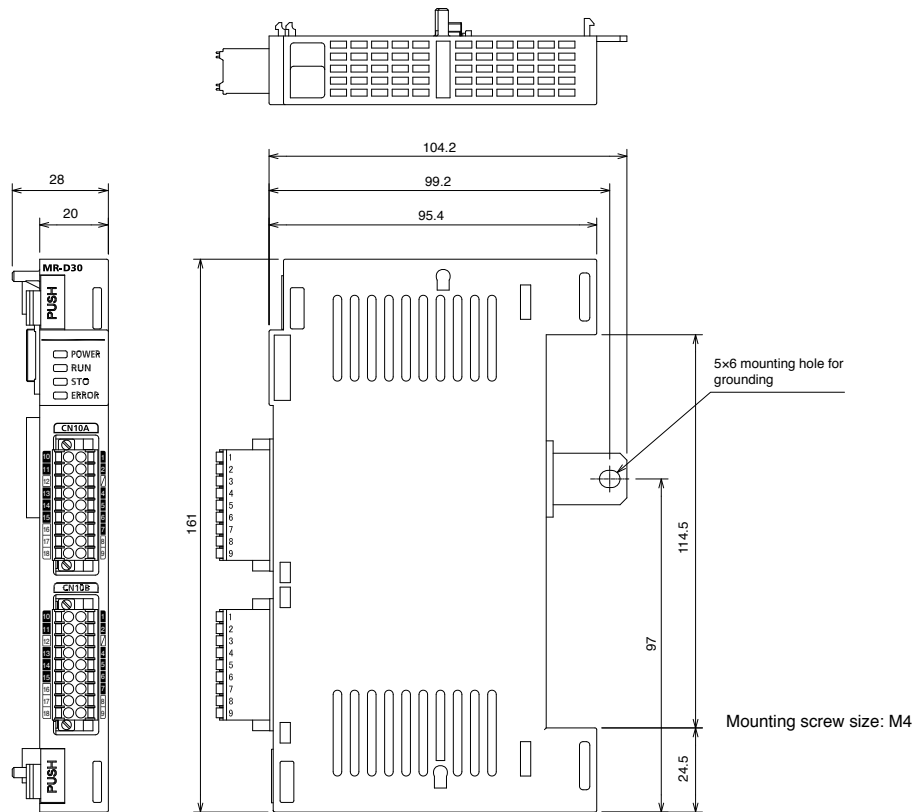

[Unit: mm]

## Product list

Item	Model
Functional safety unit	MR-D30

Item	Model	Rated output	Rated speed	
Servo motors with functional safety HG-KR series  B: With electromagnetic brake	HG-KR053(B)W0C	50 W	3000 r/min	
	HG-KR13(B)W0C	100 W	3000 r/min	
	HG-KR23(B)W0C	200 W	3000 r/min	
	HG-KR43(B)W0C	400 W	3000 r/min	
	HG-KR73(B)W0C	750 W	3000 r/min	
Servo motors with functional safety HG-SR 1000 r/min series  B: With electromagnetic brake	HG-SR51(B)W0C	0.5 kW	1000 r/min	
	HG-SR81(B)W0C	0.85 kW	1000 r/min	
	HG-SR121(B)W0C	1.2 kW	1000 r/min	
	HG-SR201(B)W0C	2.0 kW	1000 r/min	
	HG-SR301(B)W0C	3.0 kW	1000 r/min	
Servo motors with functional safety HG-SR 2000 r/min series  B: With electromagnetic brake	200 V class	HG-SR52(B)W0C	0.5 kW	2000 r/min
		HG-SR102(B)W0C	1.0 kW	2000 r/min
		HG-SR152(B)W0C	1.5 kW	2000 r/min
		HG-SR202(B)W0C	2.0 kW	2000 r/min
		HG-SR352(B)W0C	3.5 kW	2000 r/min
		HG-SR502(B)W0C	5.0 kW	2000 r/min
	400 V class	HG-SR702(B)W0C	7.0 kW	2000 r/min
		HG-SR524(B)W0C	0.5 kW	2000 r/min
		HG-SR1024(B)W0C	1.0 kW	2000 r/min
		HG-SR1524(B)W0C	1.5 kW	2000 r/min
		HG-SR2024(B)W0C	2.0 kW	2000 r/min
		HG-SR3524(B)W0C	3.5 kW	2000 r/min
		HG-SR5024(B)W0C	5.0 kW	2000 r/min
Servo motors with functional safety HG-JR 1500 r/min series  B: With electromagnetic brake	200 V class	HG-JR701M(B)W0C <sup>(Note 1)</sup>	7.0 kW	1500 r/min
		HG-JR11K1M(B)W0C <sup>(Note 1)</sup>	11 kW	1500 r/min
		HG-JR15K1M(B)W0C <sup>(Note 1)</sup>	15 kW	1500 r/min
		HG-JR22K1MW0C <sup>(Note 1)</sup>	22 kW	1500 r/min
	400 V class	HG-JR701M4(B)W0C <sup>(Note 1)</sup>	7.0 kW	1500 r/min
		HG-JR11K1M4(B)W0C <sup>(Note 1)</sup>	11 kW	1500 r/min
		HG-JR15K1M4(B)W0C <sup>(Note 1)</sup>	15 kW	1500 r/min
		HG-JR22K1M4W0C <sup>(Note 1)</sup>	22 kW	1500 r/min
Servo motors with functional safety HG-JR 3000 r/min series  B: With electromagnetic brake	200 V class	HG-JR53(B)W0C	0.5 kW	3000 r/min
		HG-JR73(B)W0C	0.75 kW	3000 r/min
		HG-JR103(B)W0C	1.0 kW	3000 r/min
		HG-JR153(B)W0C	1.5 kW	3000 r/min
		HG-JR203(B)W0C	2.0 kW	3000 r/min
		HG-JR353(B)W0C	3.3 kW (3.5 kW)	3000 r/min
		HG-JR503(B)W0C	5.0 kW	3000 r/min
		HG-JR703(B)W0C	7.0 kW	3000 r/min
	400 V class	HG-JR903(B)W0C	9.0 kW	3000 r/min
		HG-JR534(B)W0C	0.5 kW	3000 r/min
		HG-JR734(B)W0C	0.75 kW	3000 r/min
		HG-JR1034(B)W0C	1.0 kW	3000 r/min
		HG-JR1534(B)W0C	1.5 kW	3000 r/min
		HG-JR2034(B)W0C	2.0 kW	3000 r/min
		HG-JR3534(B)W0C	3.3 kW (3.5 kW)	3000 r/min
		HG-JR5034(B)W0C	5.0 kW	3000 r/min
		HG-JR7034(B)W0C	7.0 kW	3000 r/min
HG-JR9034(B)W0C	9.0 kW	3000 r/min		

Notes: 1. Available in the near future.



MEMO



---

**MEMO**

 **Safety Warning**

To ensure proper use of the products listed in this catalog, please be sure to read the instruction manual prior to use.

# SERVO AMPLIFIERS & MOTORS

Country/Region	Sales office	Tel/Fax
USA	MITSUBISHI ELECTRIC AUTOMATION, INC. 500 Corporate Woods Parkway, Vernon Hills, IL 60061, U.S.A.	Tel : +1-847-478-2100 Fax : +1-847-478-2253
Mexico	MITSUBISHI ELECTRIC AUTOMATION, INC. Mexico Branch Mariano Escobedo #69, Col. Zona Industrial, Tlalnepantla Edo, C.P.54030, Mexico	Tel : +52-55-3067-7500 Fax : -
Brazil	MITSUBISHI ELECTRIC DO BRASIL COMÉRCIO E SERVIÇOS LTDA. Rua Jussara, 1750- Bloco B Anexo, Jardim Santa Cecilia, CEP 06465-070, Barueri - SP, Brasil	Tel : +55-11-4689-3000 Fax : +55-11-4689-3016
Germany	MITSUBISHI ELECTRIC EUROPE B.V. German Branch Gothaer Strasse 8, D-40880 Ratingen, Germany	Tel : +49-2102-486-0 Fax : +49-2102-486-1120
UK	MITSUBISHI ELECTRIC EUROPE B.V. UK Branch Travellers Lane, Hatfield, Hertfordshire, AL10 8XB, U.K.	Tel : +44-1707-28-8780 Fax : +44-1707-27-8695
Italy	MITSUBISHI ELECTRIC EUROPE B.V. Italian Branch Centro Direzionale Colleoni - Palazzo Sirio Viale Colleoni 7, 20864 Agrate Brianza(Milano) Italy	Tel : +39-039-60531 Fax : +39-039-6053-312
Spain	MITSUBISHI ELECTRIC EUROPE, B.V. Spanish Branch Carretera de Rubí, 76-80-Apdo. 420, 08173 Sant Cugat del Vallés (Barcelona), Spain	Tel : +34-935-65-3131 Fax : +34-935-89-1579
France	MITSUBISHI ELECTRIC EUROPE B.V. French Branch 25, Boulevard des Bouvets, F-92741 Nanterre Cedex, France	Tel : +33-1-55-68-55-68 Fax : +33-1-55-68-57-57
Czech Republic	MITSUBISHI ELECTRIC EUROPE B.V. Czech Branch Avenir Business Park, Radlicka 751/113e, 158 00 Praha5, Czech Republic	Tel : +420-251-551-470 Fax : +420-251-551-471
Poland	MITSUBISHI ELECTRIC EUROPE B.V. Polish Branch ul. Krakowska 50, 32-083 Balice, Poland	Tel : +48-12-630-47-00 Fax : +48-12-630-47-01
Russia	MITSUBISHI ELECTRIC EUROPE B.V. Russian Branch St. Petersburg office Piskarevsky pr. 2, bld 2, lit "Sch", BC "Benua", office 720; RU-195027 St. Petersburg, Russia	Tel : +7-812-633-3497 Fax : +7-812-633-3499
Sweden	MITSUBISHI ELECTRIC EUROPE B.V. (Scandinavia) Fjellievägen 8, SE-22736 Lund, Sweden	Tel : +46-8-625-10-00 Fax : +46-46-39-70-18
Turkey	MITSUBISHI ELECTRIC TURKEY A.Ş Ümraniye Branch Şerifali Mahallesi Nutuk Sokak No:5, TR-34775 Ümraniye, İstanbul, Turkey	Tel : +90-216-526-3990 Fax : +90-216-526-3995
UAE	MITSUBISHI ELECTRIC EUROPE B.V. Dubai Branch Dubai Silicon Oasis, P.O.BOX 341241, Dubai, U.A.E.	Tel : +971-4-3724716 Fax : +971-4-3724721
South Africa	ADROIT TECHNOLOGIES 20 Waterford Office Park, 189 Witkoppen Road, Fourways, Johannesburg, South Africa	Tel : +27-11-658-8100 Fax : +27-11-658-8101
China	MITSUBISHI ELECTRIC AUTOMATION (CHINA) LTD. No.1386 Hongqiao Road, Mitsubishi Electric Automation Center, Shanghai, China	Tel : +86-21-2322-3030 Fax : +86-21-2322-3000
Taiwan	SETSUYO ENTERPRISE CO., LTD. 6F, No.105, Wugong 3rd Road, Wugu District, New Taipei City 24889, Taiwan, R.O.C.	Tel : +886-2-2299-2499 Fax : +886-2-2299-2509
Korea	MITSUBISHI ELECTRIC AUTOMATION KOREA CO., LTD. 7F-9F, Gangseo Hangang Xi-tower A, 401, Yangcheon-ro, Gangseo-Gu, Seoul 157-801, Korea	Tel : +82-2-3660-9510 Fax : +82-2-3664-8372/8335
Singapore	MITSUBISHI ELECTRIC ASIA PTE. LTD. 307, Alexandra Road, Mitsubishi Electric Building, Singapore 159943	Tel : +65-6473-2308 Fax : +65-6476-7439
Thailand	MITSUBISHI ELECTRIC FACTORY AUTOMATION (THAILAND) CO., LTD. 12th Floor, SV.City Building, Office Tower 1, No. 896/19 and 20 Rama 3 Road, Kwaeng Bangpongpan, Khet Yannawa, Bangkok 10120, Thailand	Tel : +66-2682-6522 to 6531 Fax : +66-2682-6020
Indonesia	PT. MITSUBISHI ELECTRIC INDONESIA Gedung Jaya 11th Floor, JL. MH. Thamrin No.12, Jakarta Pusat 10340, Indonesia	Tel : +62-21-3192-6461 Fax : +62-21-3192-3942
Vietnam	MITSUBISHI ELECTRIC VIETNAM COMPANY LIMITED Unit 01-04, 10th Floor, Vincom Center, 72 Le Thanh Ton Street, District 1, Ho Chi Minh City, Vietnam	Tel : +84-8-3910-5945 Fax : +84-8-3910-5947
India	MITSUBISHI ELECTRIC INDIA PVT. LTD. Pune Branch Emerald House, EL -3, J Block, M.I.D.C Bhosari, Pune - 411026, Maharashtra, India	Tel : +91-20-2710-2000 Fax : +91-20-2710-2100
Australia	MITSUBISHI ELECTRIC AUSTRALIA PTY. LTD. 348 Victoria Road, P.O. Box 11, Rydalmere, N.S.W 2116, Australia	Tel : +61-2-9684-7777 Fax : +61-2-9684-7245

Mitsubishi Electric Corporation Nagoya Works is a factory certified for ISO14001 (standards for environmental management systems) and ISO9001 (standards for quality assurance management systems)

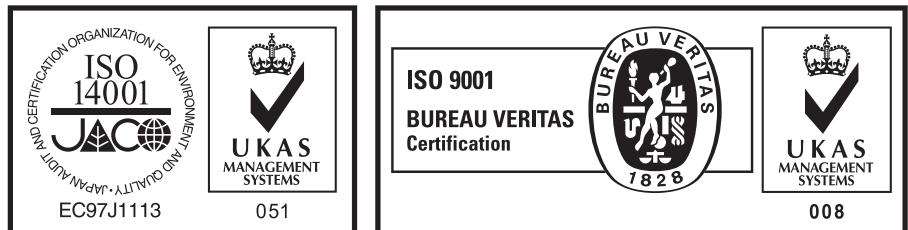

## MITSUBISHI ELECTRIC CORPORATION

HEAD OFFICE: TOKYO BUILDING, 2-7-3, MARUNOUCHI, CHIYODA-KU, TOKYO 100-8310, JAPAN  
NAGOYA WORKS: 1-14, YADA-MINAMI 5, HIGASHI-KU, NAGOYA, JAPAN